



BAUM



**714XAB-2-P-1
714XAB-2-P-4**

**TABLE TOP FOLDER
INSTRUCTION MANUAL**

**FOR INSTRUCTION MANUALS IN SPANISH, FRENCH, AND GERMAN
GO TO WWW.BAUMFOLDER.COM**

©2010 BAUMFOLDER CORPORATION
All Rights Reserved

WARNING

- Do not operate this machine without all guarding in place.
- Do not make adjustments or perform maintenance on this machine with power on.
- Keep the machine and the work area clean and free of spills to prevent accidents.
- Be sure to replace any safety decals that may have been detached for any reason.

Baumfolder Corporation reserves the right to make changes in design or to make additions or improvements in its products without imposing any obligation upon itself to install them on its previously manufactured products. It is recommended that modifications to this equipment not be made without the advice and express written consent of Baumfolder Corporation.

FOLDER IDENTIFICATION

MODEL NO: _____ SERIAL NO: _____

SALES AGENCY: _____

INSTALLED BY: _____ DATE: _____

PHONE NO: _____

CONTENTS

INTRODUCTION

SAFETY FIRST.....6

INTRODUCTION OVERVIEW 7

1.0 ASSEMBLY INSTRUCTIONS 7

1.1 INSTALL FEED TABLE 8

1.2 INSTALL BOTH PANS 8

1.3 INSTALL STACKER TRAY.....9

1.4 PUMP CONNECTIONS 9

1.5 INSTALL SLITTER SHAFT ASSEMBLY 9

1.6 OTHER ELECTRICAL CONNECTIONS 9

2.0 SETUP.....9

2.1 GAP ADJUSTMENT 9

2.2 FEED TABLE ADJUSTMENT 9

2.3 AIR FLOW ADJUSTMENT 10

3.0 OPERATION.....10

3.1 LOADING THE FEED TABLE 10

3.2 CHECK SQUARENESS OF FOLD 10

3.3 USE OF HANDWHEEL 10

4.0 PERFORATING, SCORING & SLITTING 11

4.1 PERFORATING 11

4.2 SCORING 12

4.3 SLITTING 12

5.0 MAINTENANCE 13

5.1 MAINTNANCE AND CARE OF YOUR 714XA.....13

5.2 LUBRICATION.....13

5.3 CLEANING OF FOLD ROLLS.....13

5.4 CLENING FILTER13

5.5 PHOTO SENSORS.....13

CONTENTS

DESCRIPTION	PAGE
6.0 BAUMFOLDER 714XA “QUICK START” INSTRUCTIONS	14
TURNING THE MAIN SWITCH ON	14
CURRENT JOB OR SETUP NEW JOB	14
FOLD CHOICE SCREEN	14
PAPER LENGTH SCREEN	14
SELECTING UNITS	14
MOVING PANS (INITIALIZING OR MOVING TO FOLD POSITION)	15
PAN MOVING STATUS IMAGE	15
COUNT SETUP SCREEN :BATCH OR NO BATCH	15
COUNT SETUP SCREEN :RUN BATCH-SIMPLE	16
COUNT SETUP SCREEN: RUN BATCH-VARIABLE	17
VARIABLE BATCH SETUP SCREEN	17
VARIABLE BATCH DATA ENTRY SCREEN	17
PRODUCTION SCREEN ICONS	18
CURRENT FOLD TYPE	18
PAN 1 AND PAN 2 CURRENT POSITIONS	18
TURNING ON MAIN ROLLS, DELIVERY, AND PUMP	19
SINGLE SHEET MODE/ CONTINUOUS FEED MODE	19
PAPER FEED ON/ OFF.....	20
TOTAL COUNT INDICATOR AND RESET COUNT BUTTON	20
BATCH COUNT INDICATORS.....	20
PREVIOUS SCREEN REQUEST BUTTON	20
MAIN SCREEN REQUEST BUTTON	20
PRODUCTION SCREEN REQUEST BUTTON	20
FOLD PAN ADJUSTMENT SCREEN	21
FOLD PAN DIRECT ENTRY SCREEN	21
SETUP PREFERENCES SCREEN	22
LANGUAGE SELECTION	22
SENSOR BYPASS OPTIONS	22
MEMORY SCREEN	23
SAVE TO MEMORY SCREEN	24
RELOAD FROM MEMORY SCREEN	24
FAULT STATES.....	24
NON-FAULT STAUS INDICATORS	25
ERROR SCREENS	26
7.0 OPERATOR CONTROLS	27
7.0 SETTING FOLDING SPEED	27
7.1 SETTING STACKER BELT SPEED	27
7.2 EMERGENCY STOP BUTTON	27

CONTENTS

8.0 BASIC MACHINE SETUP	28
8.1 UNITS OF MEASURE	28
8.2 LANGUAGES	28
8.3 HARDWARE AND SOFTWARE VERSIONS	28
9.0 DIAGNOSTICS	28
10.0 CALIBRATION OF FOLD PANS	29
TECHNICAL SPECIFICATIONS.....	43
TROUBLESHOOTING	44
INSTALLATION OF ANTISTATIC.....	45



SAFETY FIRST



Your new Baum paper folding machine has been designed in accordance with the latest safety specifications. The warning and caution labels on the machine must remain in place. Make sure all guarding provided is in place before starting up and running the machine.

Due to the nature of the work process of paper folding machines, there are parts and areas on the machine which cannot be completely covered without interfering with the operation of the machine. Therefore, sound personal work habits and strict observance of all safety precautions is required for the protection of the operator, co-workers, and the machine.

Be sure to follow these safety precautions:

1. Study the safety instructions at your plant and those provided in this manual.
2. Study the operating instructions carefully before operating the machine.
3. Make sure that your co-workers are familiar with the work process, potential danger areas, and all necessary safety measures.
4. Make sure that the machine is in good working order before turning it on.
5. If the machine suddenly stops for whatever reason, do not restart it right away. Someone may have stopped the machine, but failed to press the emergency (Stop) button. If the machine is restarted unexpectedly, your co-worker could be seriously injured.
6. Always press the emergency (Stop) button first if you stop the machine for adjustments or maintenance work which must not be done while the machine is in operation.
7. For extensive maintenance or repair work, turn off the main power supply.
8. Never use improper or defective tools.
9. After making adjustments or after doing maintenance or repair work, always make sure that all tools and other objects are removed from the machine. Otherwise, they might fall into the machine, causing severe damage or injuries.

10. Make sure that all safety devices are in place before restarting the machine.
11. Never clean moving parts of the machine (rollers, shafts, etc.) or remove any test sheets or paper jams while the machine is running.
12. Keep the floor around the entire machine clean. Immediately clean up any oil, grease, or paint spills from the floor. Remove tools, cleaning cloths, and paper scraps from all work areas.
13. Never allow unauthorized personnel to make adjustments on the machine, remove problem sheets, or start the machine.
14. Never climb over the machine or crawl into it while it is turned on.
15. Immediately repair or replace any safety devices which have become ineffective or are missing.
16. Report any exposed cables or exposed electrical connections.
17. Always have a certified qualified electrician perform all electrical maintenance.
18. Do not make adjustments or perform maintenance with the power on.
19. Become familiar with and follow the safety labels on the next page. Replace any of these labels that are damaged or lost.

Additional Notes:

20. Do not attempt to remove a paper jam, no matter how minor it may appear to be, while the machine is running.
21. When cleaning the fold rolls, use the handwheel for turning. Be sure the power to the machine is off.
22. Turn off the machine before making any adjustments to the scoring, perforating, or slitting attachments. Keep hands and clothing away from the slitter shafts when the machine is running.



LA SEGURIDAD ES LO PRIMERO



Su nueva máquina plegadora de papel Baum ha sido diseñada de acuerdo con las más recientes especificaciones de seguridad. Las etiquetas de advertencia y precaución en la máquina deben mantenerse colocadas en su lugar. Asegúrese que todos los elementos protectores suministrados estén colocados en su lugar antes de encender y usar la máquina.

Debido a la naturaleza del proceso de trabajo de las máquinas plegadoras de papel, hay partes y áreas en la máquina que no se pueden cubrir totalmente sin interferir con el funcionamiento de la máquina. Por lo tanto, los buenos hábitos de trabajo personales y el estricto cumplimiento de todas las precauciones de seguridad son necesarios para la protección del operador, los compañeros de trabajo y la máquina.

Asegúrese de seguir estas precauciones de seguridad:

1. Estudie las instrucciones de seguridad de su planta y aquellas suministradas en este manual.
2. Estudie detenidamente las instrucciones de operación antes de utilizar la máquina.
3. Asegúrese de que sus compañeros de trabajo estén familiarizados con el proceso de trabajo, las áreas posiblemente peligrosas y todas las medidas de seguridad necesarias.
4. Asegúrese de que la máquina esté en buenas condiciones de funcionamiento antes de encenderla.
5. Si la máquina se apaga repentinamente por cualquier razón, no la encienda de nuevo inmediatamente. Alguien podría haber apagado la máquina, pero no pulsó el botón (de parada) de emergencia. Si se vuelve a encender la máquina inesperadamente, su compañero de trabajo podría sufrir una lesión grave.
6. Presione siempre primero el botón (de parada) de emergencia si detiene la máquina para realizar ajustes o tareas de mantenimiento, ya que este tipo de trabajo no debe hacerse con la máquina en funcionamiento.
7. Para los trabajos de mantenimiento o reparación extensivos, apague el interruptor principal de la alimentación eléctrica.
8. Nunca utilice herramientas inadecuadas o defectuosas.
9. Después de realizar los ajustes o después de terminar las tareas de mantenimiento o el trabajo de reparación, compruebe siempre que se hayan retirado de la máquina todas las herramientas u otros objetos. De lo contrario, esas herramientas u objetos podrían caer en la máquina y causar daños o lesiones graves.
10. Asegúrese de que todos los dispositivos de seguridad estén colocados en su lugar antes de volver a encender la máquina.
11. Nunca limpie piezas móviles de la máquina (rodillos, ejes, etc.) ni quite hojas de prueba ni elimine atascos de papel en dichas áreas.
12. Mantenga limpio el suelo alrededor de toda la máquina. Limpie inmediatamente los derrames de aceite, grasa o pintura del suelo. Retire las herramientas, los trapos de limpieza y los trozos de papel de todas las áreas de trabajo.
13. Nunca permita que personal no autorizado haga ajustes en la máquina, retire hojas que causen problemas o encienda la máquina.
14. Nunca se suba a la máquina ni se meta en ella mientras está encendida.
15. Repare o sustituya inmediatamente los dispositivos de seguridad que falten o no sean eficaces.
16. Informe de cualquier cable expuesto o conexión eléctrica expuesta.
17. Deje siempre en manos de un electricista cualificado todas las tareas de mantenimiento eléctrico.
18. No realice ajustes ni tareas de mantenimiento con la alimentación eléctrica conectada.
19. Familiarícese con las etiquetas de seguridad de la página siguiente y siga sus recomendaciones. Sustituya las etiquetas que falten o estén dañadas.

Notas adicionales:

20. No intente eliminar un atasco de papel, aunque parezca algo fácil de hacer, mientras la máquina esté funcionando.
21. Cuando limpie los rodillos plegadores, utilice la rueda de mano para girar. Asegúrese de que la alimentación eléctrica para la máquina esté desconectada.
22. Apague la máquina antes de hacer ningún ajuste a los accesorios de hendidado, perforación o corte. Mantenga las manos alejadas de los ejes de la cortadora cuando la máquina esté funcionando.

LA SÉCURITÉ AVANT TOUT

Votre nouvelle machine Baumfolder à plier le papier a été conçue conformément aux spécifications de sécurité les plus récentes. Les étiquettes d'avertissement et d'attention sur la machine doivent rester en place. Assurez-vous que tous les dispositifs de protection fournis sont en place avant de démarrer et de faire fonctionner la machine.

En raison de la nature du processus des travaux des machines à plier le papier, certaines pièces et autres zones de la machine ne peuvent pas être complètement protégées sans interférer avec son fonctionnement. C'est pourquoi des habitudes personnelles saines de travail et l'observation stricte de toutes les précautions de sécurité sont nécessaires à la protection de l'opérateur, des collègues de travail et de la machine.

Veillez observer ces précautions de sécurité :

1. Consultez les instructions de sécurité de votre usine ainsi que celles fournies dans ce manuel.
2. Consultez les instructions de fonctionnement avec attention avant de faire fonctionner la machine.
3. Assurez-vous que vos collègues de travail sont familiarisés avec les méthodes de travail, les zones de danger potentiel et toutes les mesures de sécurité nécessaires.
4. Assurez-vous que la machine est en bon état de fonctionnement avant de la mettre sous tension.
5. Si la machine s'arrête soudainement pour une raison inconnue, ne la redémarrez pas immédiatement. Quelqu'un peut avoir arrêté la machine sans avoir appuyé sur le bouton d'arrêt d'urgence. Si la machine est inopinément redémarrée, votre collègue de travail peut être sérieusement blessé.
6. Vous devez toujours appuyer d'abord sur le bouton d'arrêt d'urgence si vous interrompez le fonctionnement de la machine pour des réglages ou pour une maintenance qui ne doit pas être réalisée pendant que la machine est en fonctionnement.
7. Pour une maintenance ou des réparations importantes, l'alimentation secteur doit être interrompue.
8. N'utilisez jamais des outils inadéquats ou défectueux.
9. Après avoir procédé au réglage, à la maintenance ou à des réparations, assurez-vous toujours que la machine est débarrassée de tous les outils et autres objets utilisés. Dans le cas contraire, ils pourraient tomber dans la machine et provoquer des détériorations ou un accident grave.

10. Assurez-vous que tous les dispositifs de sécurité sont en place avant de redémarrer la machine.
11. Ne nettoyez jamais des pièces en mouvement de la machine (rouleaux, axes), ni ne retirez aucune feuille de test ou bourrage de papier lorsque la machine est en fonctionnement.
12. Le sol tout autour de la machine doit être propre. Nettoyez immédiatement l'huile, la graisse ou la peinture en cas de déversement sur le plancher. Retirez les outils, les chiffons ou les papiers de nettoyage de toutes les zones de travail.
13. Ne laissez jamais un personnel non autorisé procéder à des réglages sur la machine, retirer des feuilles de papier avec des problèmes ou démarrer la machine.
14. Ne montez jamais sur la machine ni n'y pénétrez lorsqu'elle est sous tension.
15. Réparez ou remplacez immédiatement tout dispositif de sécurité inefficace ou manquant.
16. Signalez des câbles ou des connexions électriques exposées.
17. Ayez toujours un électricien qualifié et certifié en mesure de réaliser la maintenance électrique
18. Ne procédez à aucun réglage ou à une maintenance avec la tension appliquée.
19. Familiarisez-vous avec celle-ci et appliquer les consignes des étiquettes de sécurité sur la page suivante. Remplacez ces étiquettes si elles sont endommagées ou absentes.

Remarques supplémentaires :

20. N'essayez pas d'intervenir sur un bourrage du papier, aussi insignifiant qu'il puisse paraître, lorsque la machine est en fonctionnement.
21. Lors du nettoyage des rouleaux de pliage, utilisez le volant manuel à cet effet. Assurez-vous que l'alimentation de la machine est déconnectée.
22. Mettez d'abord la machine hors tension avant de procéder à des réglages sur les outils de découpe, de perforation et de refente. Éloignez vos mains et vos vêtements des arbres lorsque la machine est en fonctionnement.



SICHERHEIT HAT VORRANG



Ihre neue Baum-Papierfalzmaschine wurde in Übereinstimmung mit den neuesten Sicherheitspezifikationen konstruiert. Die Warn- und Vorsichtsaufkleber auf der Maschine müssen angebracht bleiben. Vergewissern Sie sich, dass alle Schutzvorrichtungen angebracht sind, bevor Sie die Maschine starten und in Betrieb nehmen.

Wegen der Art des von Papier-Falzmaschinen ausgeführten Arbeitsprozesses gibt es Komponenten und Bereiche an der Maschine, die nicht ganz abgedeckt werden können, da sie ansonsten den Betrieb der Maschine stören. Daher sind gute Arbeitsgewohnheiten und eine strenge Einhaltung aller Sicherheitsmaßnahmen erforderlich, um den Schutz des Bedieners, der Mitarbeiter und der Maschine zu gewährleisten.

Befolgen Sie stets die folgenden Sicherheitsmaßnahmen:

1. Die Sicherheitsanweisungen in Ihrem Werk und in diesem Handbuch lesen.
2. Vor der Inbetriebnahme der Maschine die Bedienungsanweisungen genau durchlesen.
3. Sicherstellen, dass Ihre Mitarbeiter mit dem Arbeitsprozess, möglichen Gefahrenbereichen und allen erforderlichen Sicherheitsmaßnahmen vertraut sind.
4. Sicherstellen, dass die Maschine funktionsfähig ist, bevor sie eingeschaltet wird.
5. Wenn die Maschine plötzlich aus irgendeinem Grund stoppt, darf sie nicht sofort wieder in Betrieb genommen werden. Es könnte sein, dass jemand die Maschine angehalten hat, jedoch nicht die Notstopptaste gedrückt hat. Wenn die Maschine unerwartet neu gestartet wird, könnte Ihr Mitarbeiter ernsthaft verletzt werden.
6. Immer zuerst die Notstopptaste drücken, wenn die Maschine für Einstellungen oder Wartungsarbeiten angehalten werden muss, die nicht während des Betriebs vorgenommen werden dürfen.
7. Bei ausgedehnten Wartungs- oder Reparaturarbeiten die Hauptstromzufuhr ausschalten.
8. Auf keinen Fall falsche oder defekte Werkzeuge verwenden.
9. Nachdem Einstellungen vorgenommen oder Wartungs- bzw. Reparaturarbeiten ausgeführt wurden, muss stets sichergestellt werden, dass alle Werkzeuge und sonstigen Objekte von der Maschine entfernt werden. Ansonsten könnten sie in die Maschine hineinfallen und ernsthafte Schäden oder Verletzungen verursachen.
10. Vergewissern Sie sich, dass alle Sicherheitsvorrichtungen angebracht sind, bevor die Maschine wieder in Betrieb genommen wird.
11. Auf keinen Fall bewegliche Teile der Maschine (Walzen, Wellen usw.) reinigen bzw. keine Testbögen oder Papierstaus beseitigen, während die Maschine läuft.
12. Den Boden um die gesamte Maschine herum sauber halten. Verschüttungen von Öl, Fett oder Farbe sofort aufwischen. Werkzeuge, Reinigungstücher und Papierreste aus allen Arbeitsbereichen entfernen.
13. Auf keinen Fall zulassen, dass nicht befugtes Personal Einstellungen an der Maschine vornimmt, problematische Bögen entfernt oder die Maschine startet.
14. Auf keinen Fall über die Maschine klettern oder in sie kriechen, während sie eingeschaltet ist.
15. Alle Sicherheitsvorrichtungen, die nicht mehr wirksam sind oder fehlen, sofort reparieren oder ersetzen.
16. Alle freiliegenden Kabel oder elektrischen Anschlüsse melden.
17. Alle Wartungsarbeiten an der Elektrik müssen von einem zertifizierten, qualifizierten Elektriker durchgeführt werden.
18. Keine Einstellungen oder Wartungsarbeiten vornehmen, wenn die Stromzufuhr eingeschaltet ist.
19. Machen Sie sich mit den Sicherheitsaufklebern auf der nächsten Seite vertraut machen und befolgen Sie sie. Beschädigte oder verloren gegangene Aufkleber müssen ersetzt werden.

Zusätzliche Hinweise:

20. Auf keinen Fall versuchen, einen Papierstau zu beseitigen, während die Maschine läuft, ganz gleich, wie geringfügig das Problem zu sein scheint.
21. Während der Reinigung der Falzwalzen das Handrad zum Drehen verwenden. Sicherstellen, dass die Stromzufuhr zur Maschine ausgeschaltet ist.
22. Die Maschine ausschalten, bevor Sie irgendwelche Einstellungen an den Ritzungs-, Perforier- oder Längsschneidegeräten vornehmen. Hände und Kleidung von den Messerwellen entfernt halten, während die Maschine läuft.

INTRODUCTION OVERVIEW

The 714XA consists of the following major components:

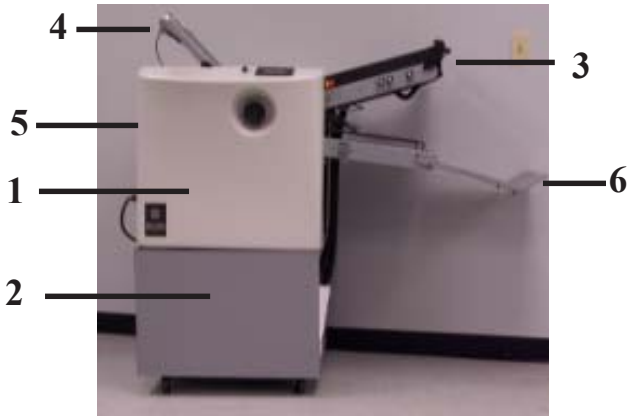

Figure 1

- 1 main unit w delivery table
- 2 cart w pump
- 3 feed table
- 4 pan 1
- 5 pan 2
- 6 stacker tray
- 7 accessories kit

TRANSPORTATION/INSTALLATION

As soon as you receive your new folder, and before removing the machine from the skid, check carefully for any damage to the shipments. If any damage is found, promptly contact your Baumfolder sales representative.

To lift the folder from the skid, place the fork lift rails under the lower rails as shown in Figure 2. Note that the fork lift must have at least a 1500 lb. capacity.

Remove all rust protection coating after unpacking the folder.



Figure 2

WARNING

Do not plug the power cord into an AC outlet until the 714XA is fully assembled, adjusted and ready to use. Unplug the 714XA an time disassembly is required.

ASSEMBLY INSTRUCTIONS

1.0 SET MAIN UNIT ON TOP OF CART ASSY

Note orientation in Figure 3. The covered end of the cart with the oval cut out for the pump power cord should be directly below the power entry bracket mounted in the left lower edge to the front guard.

Align inside of each frame to the four brackets on top of the cart assembly and attach with (8) M6 internal tooth lock washers (260-304-09-00) and (8) socket head M6x10 screws (262-320-04-00).

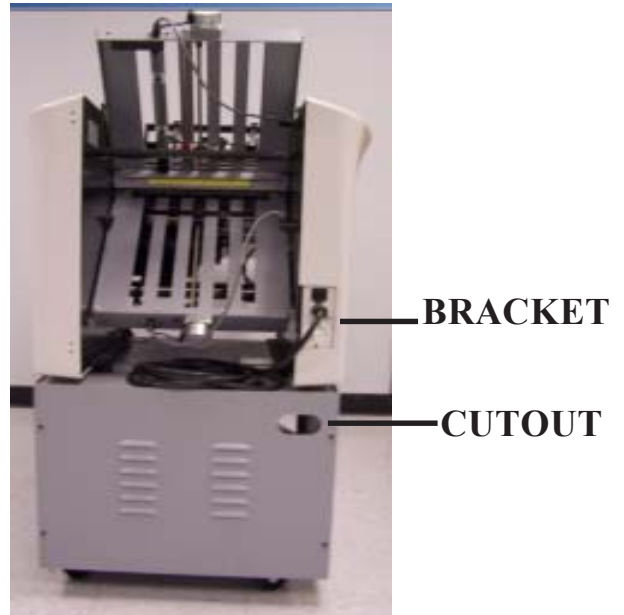

Figure 3

1.1 INSTALL FEED TABLE

See **Figure 4**. Place feed table with feed wheel toward the rolls. Slide the front knotch onto locating pins (1) and rotate the back end of the table downward to rest on upper dowel pins (2). Identical pins on both frames.

Rotate the handwheel to make sure the gears mesh.

Identify cable connected to the bottom of the feed table. Engage the other end of this cable to the mating circular din connector mounted in front frame. Turn rotating collar CW to lock in place.

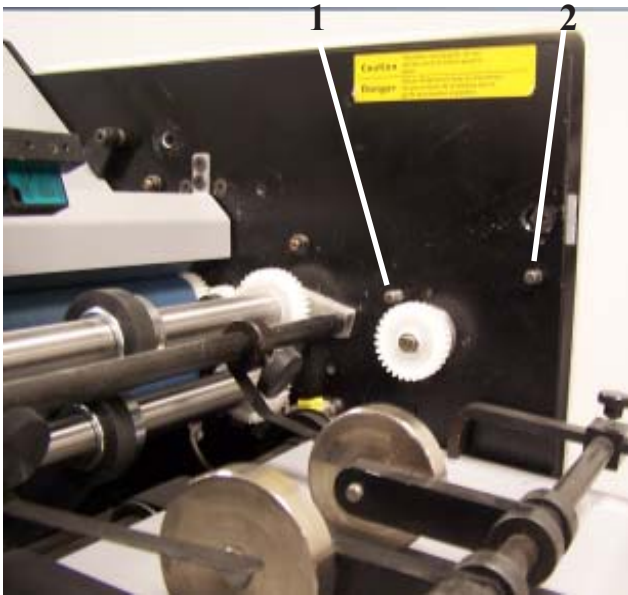

Figure 4

1.2 INSTALL BOTH FOLD PANS

The fold pans are identical.

See **Figure 5** for positioning:

Pan 1 sets on pins 1 and 2

Pan 2 sets on pins 5 and 6

Rubber hold downs 3 and 7

Pan 1's mating connector is 4

Pan 2's mating connector is 8

Insert one pan into pan 1 position. With motor end of pan towards the person installing the pan, angle front end down and set onto locating pins (1). Rotate back end down until center knotch is seated onto second set of locating pins (2). Two rubber hold downs on top of the pan now need to be rotated into position to hold the pan (3). Locate a cable attached to the back end of the pan and engage the opposite end into the mating circular din connector near the top of the front frame (4). Rotate this collar CW to lock in place.

Repeat for pan 2 except angle front end of this pan upward. Engage its cable connector into mating connector about half way down the left edge of the front frame (8).

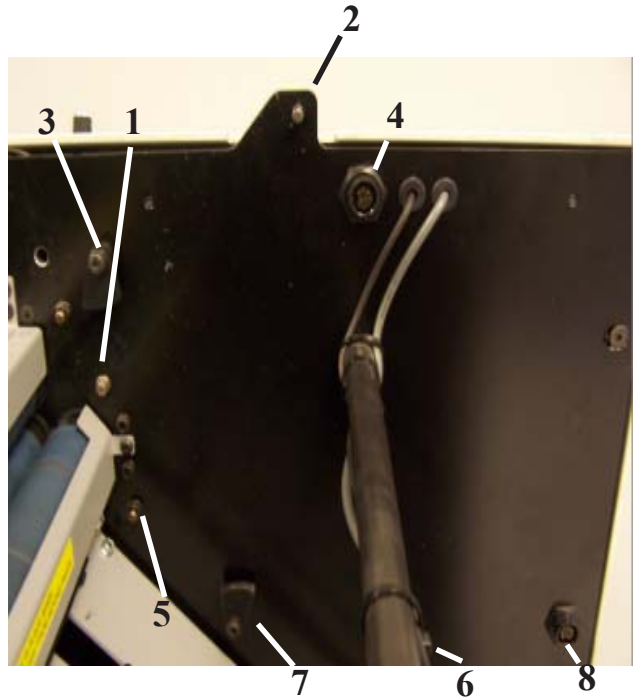

Figure 5

MANUALLY TURN THE HAND WHEEL AFTER INSTALLING BOTH PANS TO MAKE SURE NEITHER PAN IS RUBBING AGAINST THE ROLLS.

1.3 INSTALL STACKER TABLE TRAY

To install the stacker table tray, loosen the knobs on either side of the tray. Drop the tray over the knobs and retighten.

1.4 PUMP CONNECTIONS

1.41 PNEUMATIC CONNECTIONS

SEE FIGURE 7

Attach the vacuum side of the pump to the white elbow at (1A). A second 1" hose should connect from the white connect (1B).

The blow hose from the pump should connect to the black connector at (2A). A second 1" hose should connect from black connector to fitting on the solenoid manifold (2B).

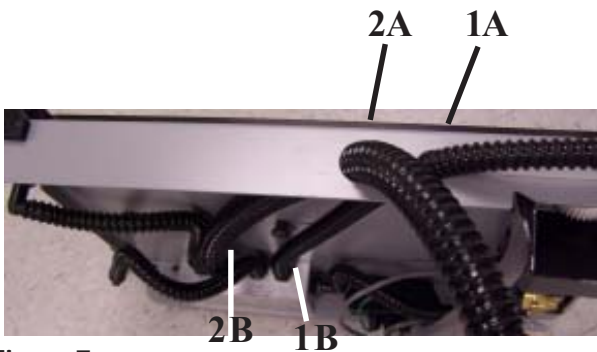

Figure 7

1.42 ELECTRICAL CONNECTIONS

The pump has a plug/cord set attached. This plug fits directly into the receptacle mounted in a bracket with a cut out in the lower left side of the front guard. See figure 3.

1.5 SLITTER SHAFT INSTALLATION

To install the slitter shaft, hold it with the grooves in the boxing down. Be sure the slitter shafts are free turning.

Insert the slitter shaft and seat the grooves in the boxings on the lower locating pins in the side frames.

Check for proper gear engagement between the upper slitter shaft gear and the 19-tooth frame idler gear by turning the hand wheel.

1.6 OTHER CONNECTIONS

Refer to the serial number plate for electrical requirements. The serial number plate notes the voltage, phase and hertz, total machine amperage, and minimum wire conductor size for the main power connection.

For the 110VAC 60 Hz version a 20A dedicated line is required.

All electrical connections are to be made by a certified electrician. Refer to local building electrical codes for proper and safe connections.

2.0 SETUP

2.1 GAP ADJUSTMENT

The orange tab above the sucker wheel assembly on the feed table must be adjusted for each new weight of paper. See Figure 8.

Slide two sheets of paper between the tab and the sucker wheel (or fold a single sheet and use the double thickness). Turn the gap knob (1) counter clockwise to tighten until there is a slight drag on the paper when you pull the double thickness of paper away from the orange tab. Remove the paper. The correct gap is now set.

2.2 FEED TABLE ADJUSTMENT

On the paper feed table there are two guides which keep the stack of paper properly aligned for feeding into the folder. Adjust these guides to correspond with the different widths of paper being fed. See black bars in Figure 8.

To adjust the paper feed guides, loosen the two side guide locking knobs on each guide (2). Slide the guides from side to side until the inside edge of each guide is aligned with the number corresponding to the width of the paper being folded.

Square the guides to the rolls using a sheet of paper. Lay a sheet of paper in the feeder, close to but not touching the side guides. Push the sheet down just to the nip of the rolls. Then align the guide by loosening the adjusting knobs and aligning the guide so that it is parallel to the edge of the paper. When one side is square, the other side can be moved into position.

Tighten the locking knobs to secure the paper guides into position.

When you load the actual job, you may have to move these guides slightly to take care of variations in sheet size. To feed properly, the paper must slide freely between these guides.

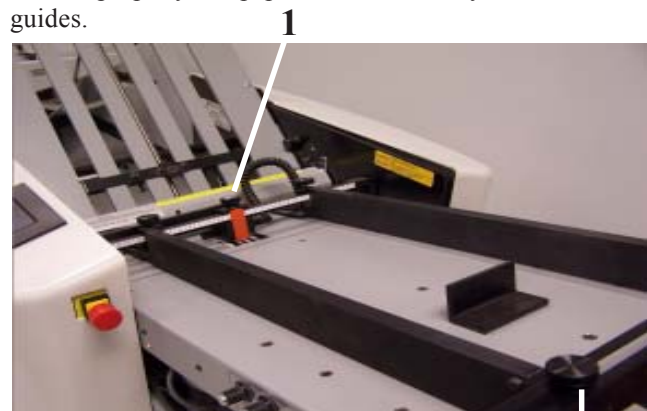

Figure 8

2

2.3 AIRFLOW ADJUSTMENTS

There are three knobs on the side of the feed table. See **Figure 9**. Two knob have nintey degrees of rotation. Clock-wise movement of each valve these two values decreases the settings.

The one closest to the main unit is the vacuum control adjustment **(1)**. Adjust the vacuum to draw the sheet down toward the sucker wheel assembly. Heavier paper weights will require more suction. Full CCW is the maximum vacuum setting.

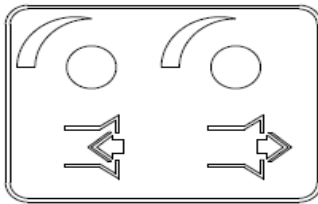

1

2

Figure 9

The middle knob **(2)** controls volumn of air blown onto the feed table. The maximum setting is again full CCW. The knob furthest away from the main unit **not shown in figure 9** is a directional value. It balances air flow to the feed table from the left to right side. This valve has one hundred and eighty degrees of adjustment. The center of this adjustment should create equal flow to both sides of the feed table. Turning it to the left or right of this position should create more air flow to one side of the feed table. Adjust these two knobs to create lift within the paper stack. "Floating" the stack correctly allows the lowest sheet to be drawn into the sucker wheel assembly.

3.0 Operation

3.1 Loading of Feed Table

Before running a batch, determine which way to load the paper: print side up or print side down. Use the single sheet mode to run sample sheets to determine the correct orientation.

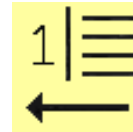

Then you can load a stack of paper no higher than two inches between the paper guides. (Please note for larger sheets or heavier bonds, the stack will be shorter.) To feed properly, the paper must "float" (See Air Flow Adjustment) and slide freely between the guides. Switch to the continuous mode to run the batch when ready. See Quick Start instruction for complete explanation page 14.



3.2 Check Squareness of Fold

Examine the folded sheets on the stacker to make sure you are getting an even and square fold.

There is a skew adjustment on each pan to adjust for a square fold on paper that is not cut perfectly square. There is a large black thumbscrew mounted to the deflector bar for this adjustment. There is also a scribe mark on the brace behind the deflector bar. This scribe is intended for a reference when making this adjustment. Please make sure paper guides are adjusted to feed paper squarely with respect to the rolls before making this adjustment.

3.3 Use of Handwheel

The handwheel is used to help clear jams and for setup. To use the handwheel, shut off the main fold rolls, pull out on the handwheel, and turn in either direction.

4.0 PERFORATING, SCORING & SLITTING

In addition to folding, your 714XA can perforate, score and slit.

WARNING

Be careful when handling perforator and slitting blades. They are extremely sharp.

4.1 Perforating

The 714XA can be used to perforate either the folded sheet (to assist in making a right-angle fold) or to perforate sheets delivered flat. BAUMFOLDER supplies one standard 41-tooth perforator blade. Additional perforator blades are available through the BAUMFOLDER Parts Department.

The perforator blade should be mounted loosely to the blade holder with the retainer collar to give better support to the perforator blade. Always be sure that the flat side of the blade is against the blade holder. Loosen the brass-tipped set screws in the perforator collar and blade holder before attempting to place them on the slitter shafts.

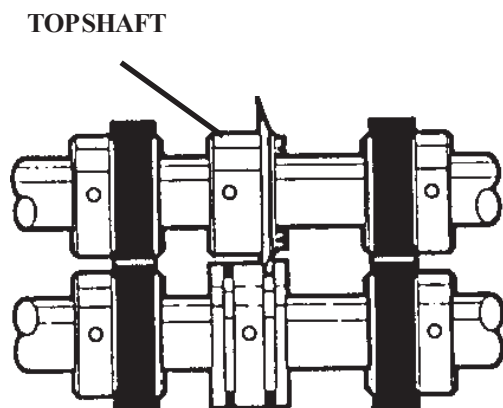

Figure 4.1-1

The perforating blade holder assembly is then slid onto the upper slitter shaft along with the necessary pull-out tire assemblies. Then tighten the screws holding the perforator blade to the blade holder, aligning the blade to the holder. This allows for free horizontal movement on the shaft.

Slide the grooved perforator collar onto the lower slitter shaft along with the other pull-out tire assemblies. The flat side of the perforator blade should just touch the side of the groove in the perforator collar. (See Figure 4.1-1)

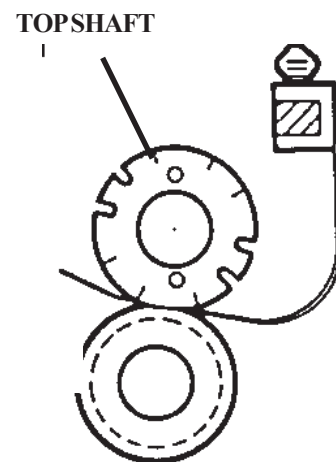

Figure 4.1-2

Slide the perforator collar and blade holder to the desired position on the slitter shaft. Then lock the blade holder and perforator collar into position with the brass-tipped set screw.

The perforator stripper fits onto the slitter shaft bar in between or next to the perforating blade. (See Figure 4.1-2) This strips the paper off for delivery and prevents it from wrapping around the perforator blade.

4.2 Scoring

The 714XA can be used to score a sheet and deliver it flat, or to score a sheet after a fold or folds have been made.

To ensure accuracy in making right-angle folds, always score the sheet where the fold is to be made. This applies in all instances when a perforator cannot be used.

Attach the scoring blade loosely to the blade holder for mounting on the slitter shaft. Scoring blades can be mounted on either the upper or lower slitter shaft. Once on the shaft, tighten the screws, aligning both the blade and the collar. This allows free horizontal movement on the shaft. Scoring blades should be placed so that the fold will be made with rather than against the scoring, or, in a continuing direction to the pressure of the crease that has been applied by the scoring blade.

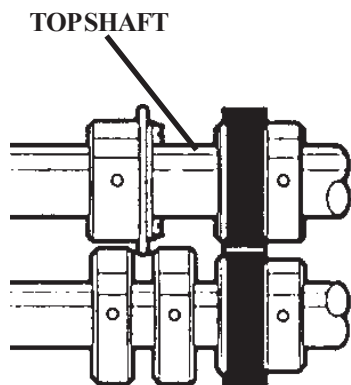

Figure 4.2-1

For a wide, well-rounded score, use the two steel scoring collars. (See Figure 4.2-1) Sharpness and the depth of the score can be controlled by regulating the distance the collars are placed away from the scoring blade.

The scoring collars can also be placed on either side of the rubber scoring collar. The two collars can be compressed against the rubber collar, causing the rubber to bulge up for a deeper score. (See Figure 4.2-2)

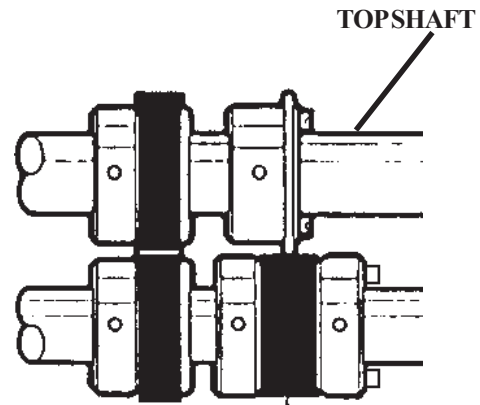

Figure 4.2-2

4.3 Slitting

NOTE: Slitting accessories are optional on your 714XA and can be ordered from your BAUMFOLDER Parts Department.

The 714XA can be used to cut folded or flat sheets apart. The general setup for blades and collars is shown in (Figure 4.3.1). Two or more cuts may be made if duplicate sets of cutters are used.

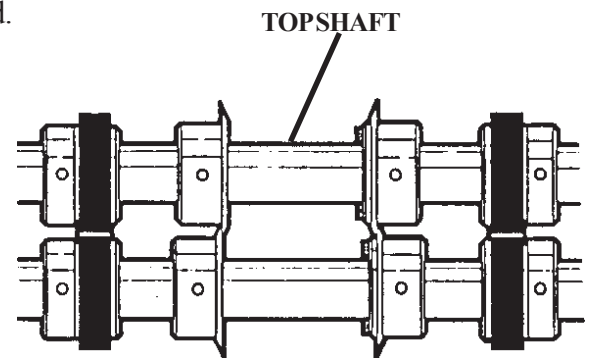

Figure 4.3.-1

Use care in mounting slitter blades to the collars in order to avoid ragged edges during slitting operations. Ragged edges can be caused by two conditions:

- 1) Nicks or burrs on the collars or blades. Remove carefully by filing or using a fine piece of emery cloth.

- 2) Incorrect mounting of blades caused by tightening with the wrong type of screw. Always use flat head screws on the side of the blade and blade holder collar, which are countersunk.

Before tightening the blade to the collar, slide the blade with the collar loosely attached on the end of the shaft. Then tighten securely, thus aligning both the blade and collar, allowing free horizontal movement along the shaft.

Place the blade, mounted on the collar, on the upper shaft in the proper position where the cut is to be made. Then move the blade and collar on the lower shaft so that the two flat edges of the blades are pressed snugly together. Too much space between the blades will produce a ragged cut.

Space the rubber pull-out tires to support the sheet.

5.0 MAINTENANCE

5.1 Maintenance and Care of your 714XA

The 714XA Air Feed has been designed to give you years of useful service, provided you maintain it according to these instructions.

5.2 Lubrication

Apply one or two drops of light machine oil at all slitter shaft bearings and the feed table bearings and idler gear once a week. Be sure to keep oil off any surface which may contact the paper.

5.3 Cleaning of Fold Rolls

Periodically wipe off the rubber surface of the fold rolls using an approved solvent such as Surewash or its equivalent. Surewash is available from BAUMFOLDER in 1-quart (P/N 24108-001) and 1-gallon (P/N 24108-002) containers. A complementary bottle of Surewash is included with your machine.

5.4 Cleaning Filters

The filters on the pump should be checked periodically and cleaned as needed. The filters can be reached by unscrewing the filter jars.

5.5 Photo Sensors

Occasionally wipe off the photo sensor with a dry cloth.

4.0 BAUMFOLDER 714XA “QUICK START” INSTRUCTIONS

1. Turn on Main Power switch on left side of the enclosure.

The display should show a **Baumfolder information screen** for 15 seconds and then automatically switches to the **Production Screen**:

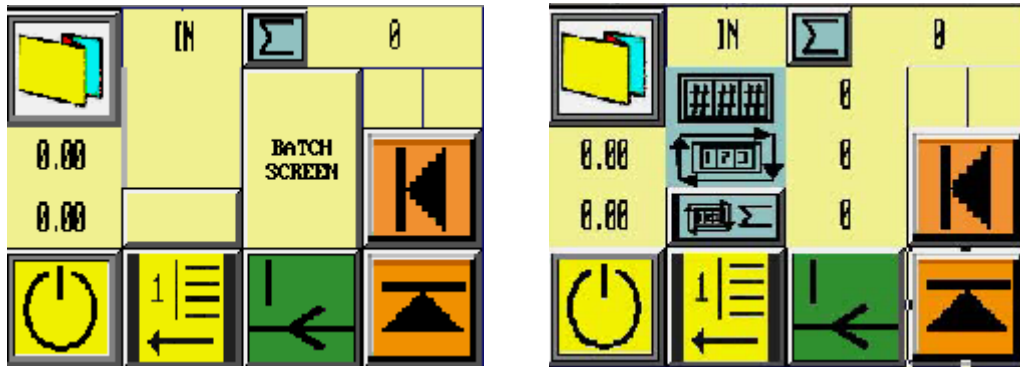

Production Screen with NO BATCH Production Screen with Batch

- The Active fold type is shown in the upper left corner of the screen of the production screen. Press this image to change to a different fold type. This changes to the **Fold Choice screen**. The selected fold choice will be in color. Press a different icon to change. If the half fold is chosen, there will be a choice of pan 1 or pan 2.

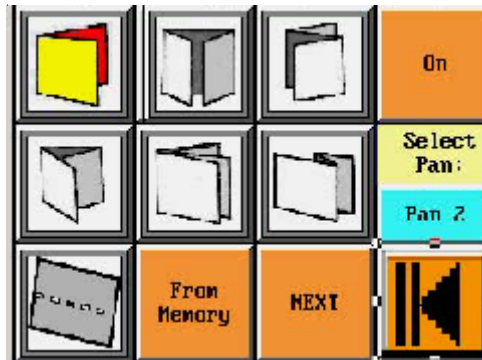

- The NEXT button changes the screen to the **Length screen**. The active units will have a blue background. Press the units with the gray background to change units. The standard sizes for metric will be shown when mm is shown in blue; the standard inch sized paper will be shown when the inch has the blue background. The blue background indicates currently selected size. To change to a different size, press a new standard size with a gray background or if you would prefer a non-standard size, enter the value directly into the bottom numeric entry.

Here is an example of the **Length Screen**:

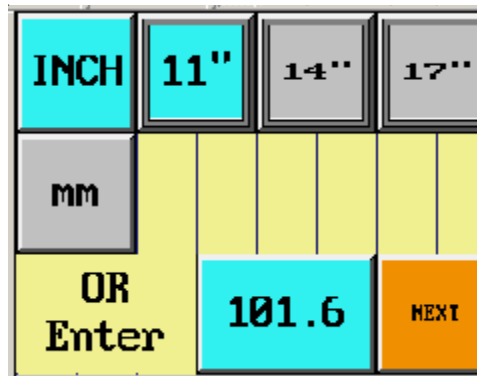

After selecting the units and the paper size, Press the NEXT button to change to the **INITIALIZATION SCREEN**:

4. After changing to the initialization screen, both pans will move into the deflect position then back out to the fold position. While the pans are moving the status icon for the pans moving will display:



After the pans have reached the requested fold position, the PANS AT FOLD POSITION message will appear. You then have a choice of returning to the production screen to run the job using the  or choosing the COUNT SETUP button to change the batch count or mode.

5. There are several ways to get to the **BATCH COUNT** screen. From the production screen, press the Batch Screen button if the mode is currently set for NO BATCH. (See the picture labeled NO BATCH on page 14 item one). If the current mode is set for BATCH then press any of the numbers to the right of the blue batch icons:



OR

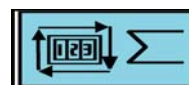

6. The first choice on the **BATCH SCREEN** is for **BATCH** or **NO BATCH**. The active choice will have a blue background.

If **NO BATCH** is chosen there are no other choices except to return to the production screen using

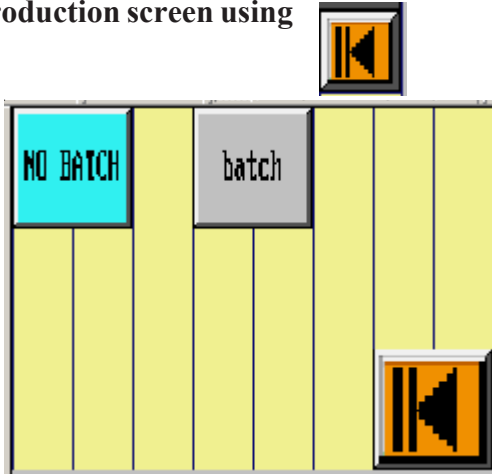

NO BATCH

The mode can be **CHANGED TO BATCH** by pressing the batch button with the gray background changing it to a blue background:

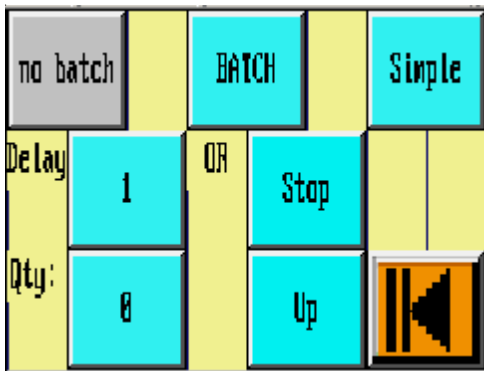

SIMPLE BATCH

For **SIMPLE BATCH** there will be choices of time **DELAY** between batches or an automatic **STOP** after the batch is complete, batch **QUANTITY**, and counting either **UP** or **DOWN**. Each active choice will have a blue background. Use the



production screen after the selections are made.

SIMPLE BATCH can be changed to **VARIABLE BATCH** by pressing the **Simple** button in the upper right of the batch screen. Each time it is pressed it will switch back and forth between **SIMPLE** and **VARIABLE**.

After Selecting the VARIABLE batch:

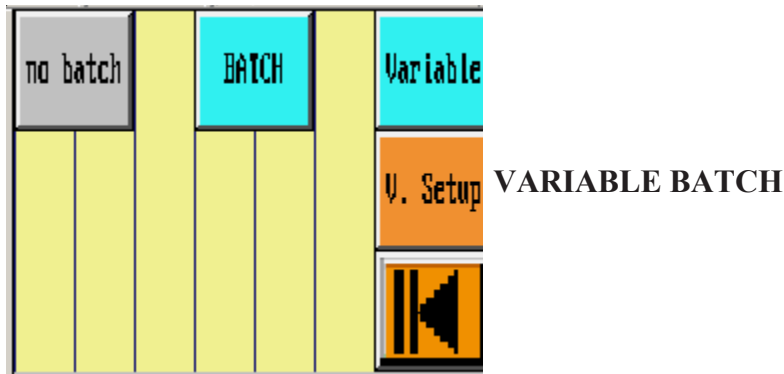

Press the V. SETUP button to continue.

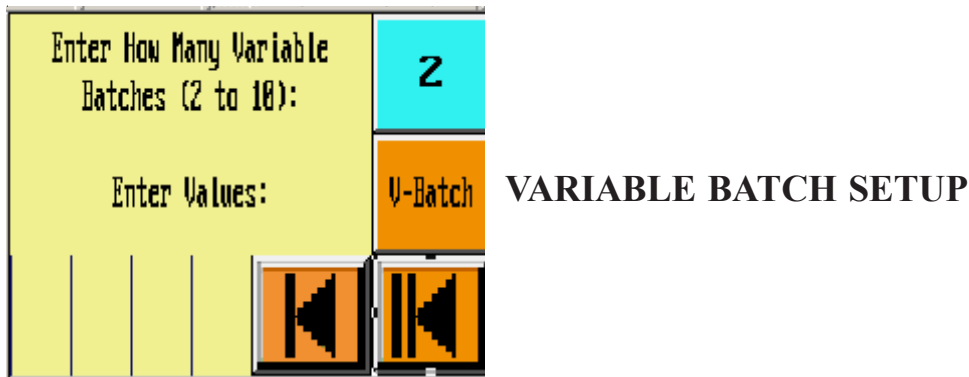

Enter the number of variable batches in this run. Then Press the V-Batch button to enter the values in each batch.

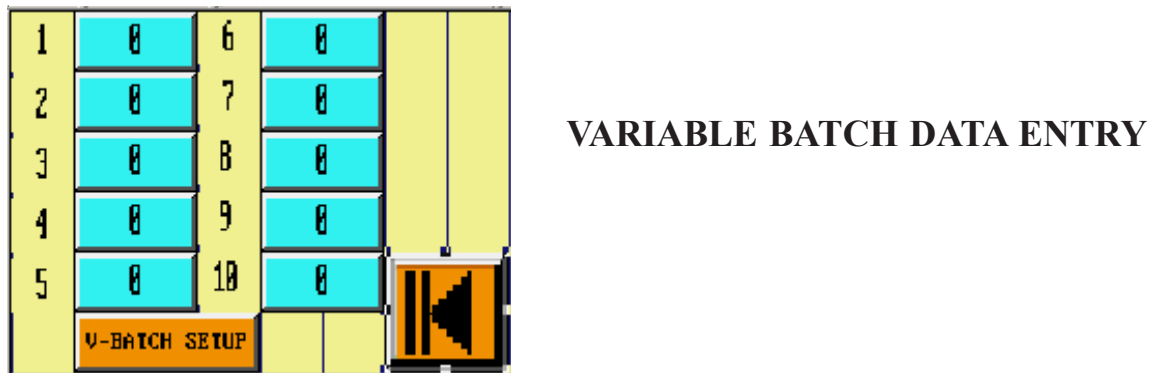

Only the number of variable batches requested in Variable batch setup will be displayed (up to 10). Enter each batch value by pressing the corresponding blue numeric input area. If Needed, return to change the number of batches using the V-Batch Setup or just use the arrow with the double bar to return to the production screen when ready to run the job.

23. Sample Production Screen:

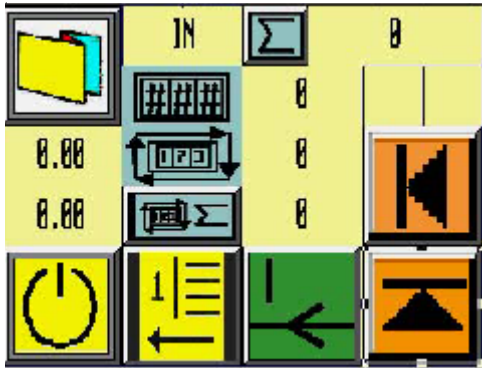

Units:

The IN or MM is the **unit indicator**.

CURRENT FOLD TYPE:

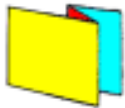

This is the **current fold indicator**. In this case it is an engineering fold. If you press this button while on the production screen, it takes you to the **Fold Selection Screen**.

PAN 1 AND PAN 2 POSITIONS:

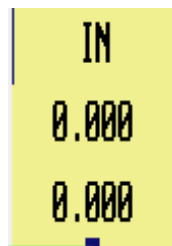

The numbers on the left side of the screen below the units display show the current position of pan 1 and pan 2. Pan 1 is on the top and Pan 2 is on the bottom.

STATUS INDICATOR AND START BUTTON:



At the bottom left is the status indicator in the “ready” state.

The status indicator on the production screen is also the button to turn the machine ON or OFF. Pressing the status indicator when it is in the “ready state” for half a second turns ON the main rolls, the pump, and the delivery.

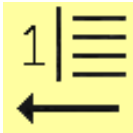

or

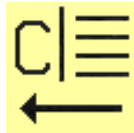

The 1 indicates single sheet mode and the C indicates continuous feed mode.

Pressing this button toggles between the two options.



This indicates **paper is not being released (fed) into the rollers.**

To feed paper in **continuous mode**, press this button to toggle feed on or off.

In the **single sheet mode**, one sheet will be released each time this button is pressed.



In Continuous mode this indicates paper is being released (fed).

In Continuous mode, pressing this button will turn the feed back off and return the button to the yellow state.

In Single Sheet mode, this state triggers only when the sheet is released, then returns to the yellow 0 image automatically.



To the right of this button is the **total count**. It can reset to zero if the button is held for 3 seconds.



To the right of this icon is **total requested in the current batch**.



To the right of this icon is the **current number run in this batch**.

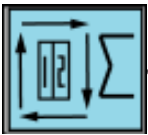

To the right of this icon is the **number of batches**. This is also a reset button to reset the number of batches run back to zero.



This button moves the display to the **Previous Screen**.

24. Main Screen:



This button moves the display to the **Main Screen**. On the main screen there are selections to move directly to most available screens.



This button is not on the production screen. When available, it changes the display to the **Production Screen**.

25. Fold Pan Adjustment Screen:

To access the adjustment screen, start from the production screen. Press either of the numbers on the left side of the screen that indicate current position of pan 1 and pan 2.

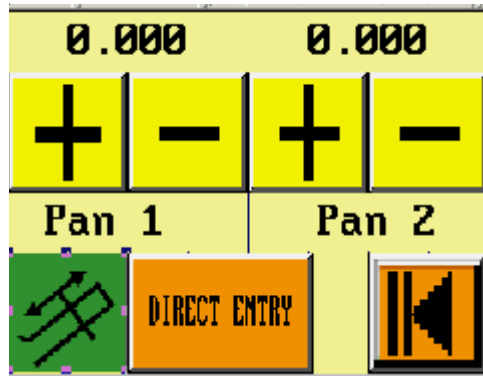

On the adjustment screen pressing either the “+” or “-” button should move the pan immediately by .01”. The status indicator will change to the pan moving status while the pan is moving and return to the “ready status” after the movement is complete. The adjustment screen is meant to correct for small changes in the pans position. A double move is required to move small distances. You can watch the pan move towards the fold roll, then away from the fold rolls. The + and - buttons will disappear while the pans are moving and then reappear after the second move is complete.

26. Fold Pan Direct Entry Screen:

To access the direct entry screen, start from the production screen, press either one of the numbers on the left side of the screen that show the current position of pan 1 and pan 2.

That should move to the adjustment screen. From the adjustment screen, press the direct entry button:

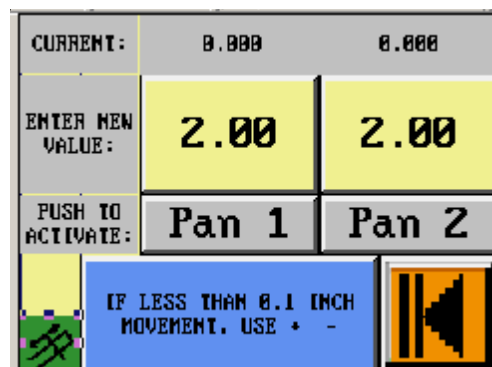

This screen will only move the pans if the movement requested is at least 0.1 inch or greater. Enter the new numeric value, then press the pan number below the new value to initiate the movement.

If less than 0.1 movement is required, press the blue button to return to the adjustment screen.

Repeat as desired for each pan. Use the  button to go to the production screen when ready.

27. Setup Preferences Screen:

To access the Setup Preferences Screen, first use the  button from any screen to access the Main

Screen (shown below):



Then select the Setup Preferences button to display Setup Preferences Screen (shown below):

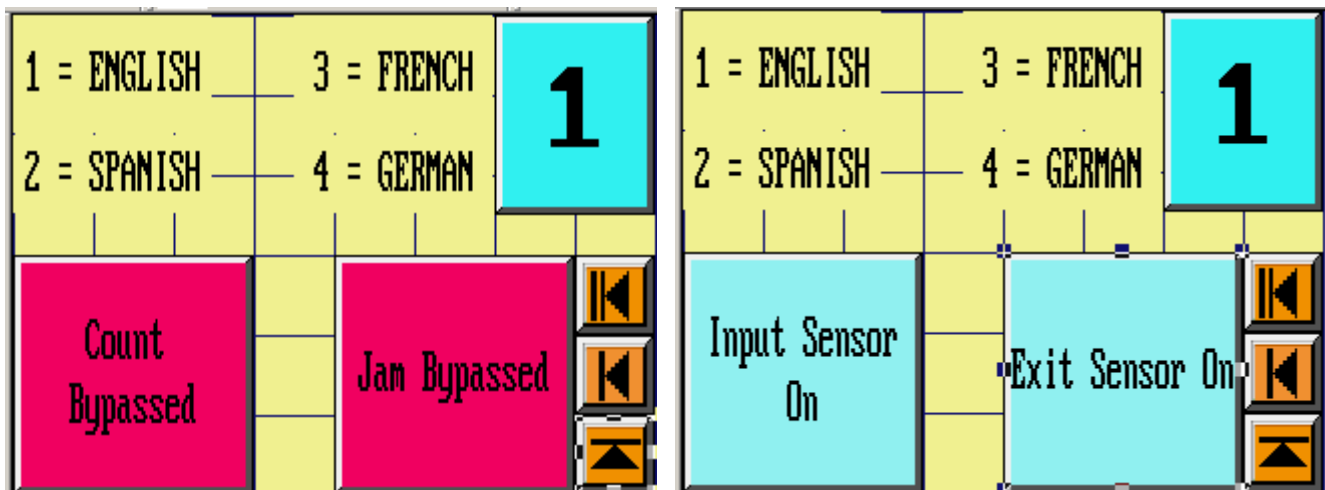

The two lower buttons toggle the sensors into and out of bypass when they are pressed. The Input Sensor is used to count, so the counts will not be correct when bypassed. The Exit Sensor triggers the jam error, so there will be no warning for a jam when this is bypassed. This option is intended to be used when a sensor is bad and a replacement is on order.

28. The Memory Screen (SAVE and RELOAD)

Before using either the Save to store a job or the Reload to recall job, check what is currently saved in the From the production screen use the  to get to the main screen:

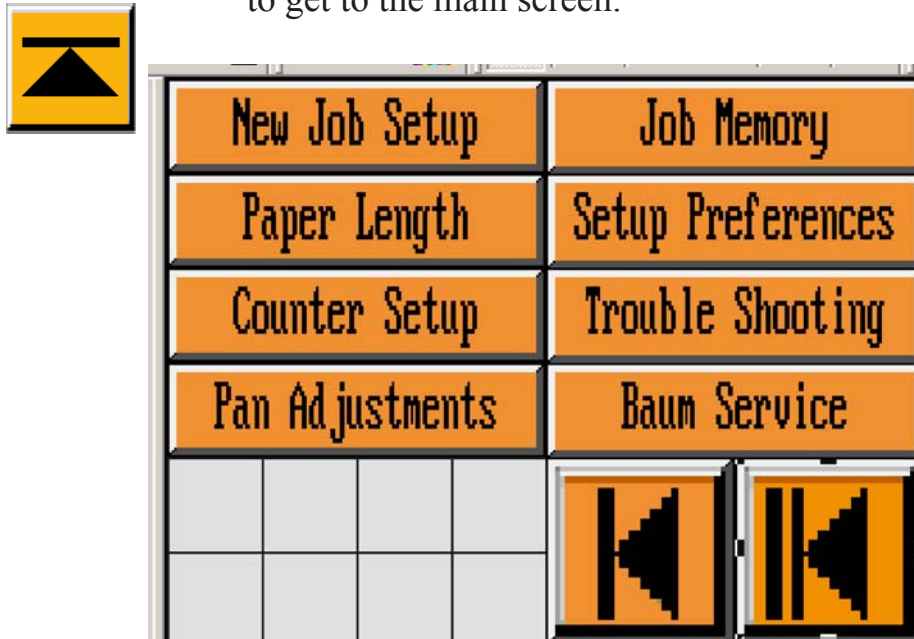

Use the JOB MEMORY button to see memory 1-4.

Before choosing either to save or reload, enter the selected memory value into the upper right box, while you can still see the options. Then use the SAVE SCREEN to save a fold into that location or the RELOAD SCREEN to recall the fold saved in that location. Alternatively, the arrow with the double lines can be used to exit this screen and go back to the production screen.

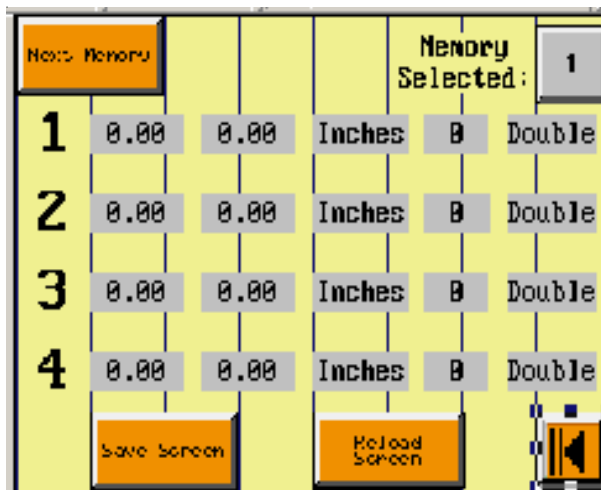

29. The Save Screen

Use the Job Memory to select a location first (See 28.) On the save screen enter the speed the job was run before saving.

Pressing the save button:  moves the current pan locations, fold type, and speed into the selected memory location.

30. The Reload Screen

Use the Job Memory to select a location first (See 28). Press the reload button:  to move data from memory to current active values on the production screen. Please remember to manually set the pot to the saved speed shown on the reload screen before returning to the production screen.

31. Status States:

Fault states include:



This indicates the emergency stop button is triggered and needs to be pulled to reset.

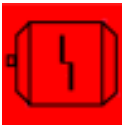

This indicates an AC drive fault. Turn power "off", allow the power to discharge, and then turn it back "on".



This indicates a paper jam on the delivery table. The jam must be removed before this fault can be cleared. Then go to the production screen and press this image on the lower left corner of the screen to reset.

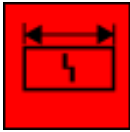

This indicates that the paper length and the fold choice are not compatible. Go to the choice screen or the paper length screen and change one of the selections.

Non- fault status states:



This state shows the machine is “ready” to start. On the production screen pressing the status button in this state will start the machine.



This state shows the machine is currently running. Pressing the status button in this state will request the machine to stop.



This state shows the machine **is in the paper clear mode**. After a regular stop is requested, this 3 second delay allows the paper in the fold pans to move through to the delivery before it stops.



This state **shows the fold pans are moving**.



This **shows the machine has reached a requested stopping**

point. This state triggers after the summation stop on a single batch is complete or the requested grouping of variable batches is completed. The operator acknowledges ready to continue by pressing this button on the production screen. Then it will return to the ready status (partial green circle).

32. Error Screens:

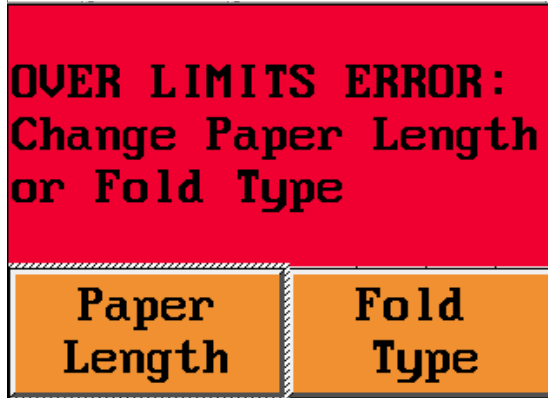

If the choice of fold or paper length created a fold length either over maximum or 14 inches or under minimum of 2 inches, instead of movement to the new position the Over limits Error screen will be the result. Use the orange buttons to change to a selection within limits.

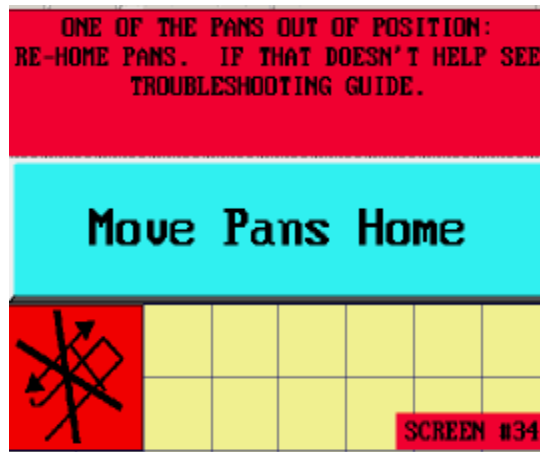

If the pans are overcycle moving to home without getting a instruction complete the Rehome pans Screen will appear. Push the Move Pans Home button to try again. If this doesn't correct the problem there is something impeding the process.

1. CHECK THAT THE COMMUNICATION CABLE TO THE PAN IS ENGAGED.
2. CHECK THAT THE HOME SWITCH FOR THE PAN IN QUESTION IS ACTIVATING CORRECTLY. (USE THE TROUBLE SHOOTING SCREEN TO MONITOR INPUTS. X3= P2 HOME AND X5=P1 HOME. IF THE HOME SWITCHES ARE NOT ACTIVATING CHECK THE POSITION OF THE HOME SWITCH. IF THE POSITION IS CORRECT, CHECK THE 24V POWER. IF THE POWER IS CORRECT, REPLACE THE HOME SWITCH.)
3. CHECK SETSCREW ON COLLAR CONNECTING THE PAN MOTOR TO THE LEAD SCREW . IF LEAD SCREW IS MISALIGNED LOOSEN THE SET SCREW, MOVE LEAD SCREW UNTIL ALIGNED, THEN RETIGHTEN.
4. IF NONE OF THESE HELP, CHECK THE 12V POWER SUPPLY. CEHCK F12. THE POWER LED ON THE A1 STEPPER BOARD. THEN CHECK THE CONNECTIONS ARE GOOD ON THE A1 SLEW CONNECTION AND THE OUTPUTS Y OF THE PLC. CHECK THE A1 Y CONNECTOR FOR PAN 2 AND THE A1 X CONNECTOR FOR PAN 1. IF ALL OF THESE ARE GOOD, THE PAN MOTOR NEEDS TO BE REPLACED.

7.0 OPERATOR CONTROLS

The main operator control panel is located at the top right of the front guard. See **Figure 10**. The "Control Panel"(1) is a full color touch sensitive screen. See Quick Start Instructions for detailed explanations (Page 14).

7.0 Setting Folding Speed

The speed of the fold rolls may be set while the folder is running! This is done by adjusting the speed control potentiometer located on the top of the front guard (2). Clockwise rotation speeds the folder up; counter-clockwise rotation slows the folder down.

7.1 Setting Stacker Belt Speed

An infinite speed range between high and low is set by turning the speed control potentiometer mounted on the side of the stacker (3). For shingling purposes use range 2 - 4. Higher speeds may be selected for use as a transfer table.

7.2 Emergency Stop Button

When an emergency stop button is pressed, the result is:

- Sheet feed - stop
- Folder drive - stop
- Delivery feed - stop
- Pump - stop

The emergency stop button must be pulled to release before the machine can be restarted. The status indicator will change to an exclamation point inside of a red triangle inside a red circle with a yellow background when the estop is active.



The emergency stop button is found on the right side of the front guard (4).

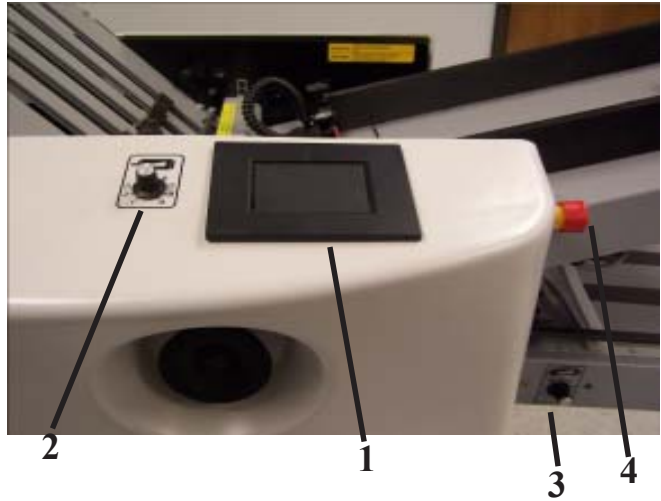

Figure 10

8.0 BASIC MACHINE SETUP

8.1: Units of Measurement

Toggles between metric and english units (mm or inches).
See Quickstart Instructions page 14.

8.2: Language

This selection specifies the Language. Available choices are ENGLISH, GERMAN, SPANISH and FRENCH. Use the Setup Preferences Screen to change languages. See Quickstart Instructions page 22.

8.3: Hardware and Software Version

This hardware versions are shown on the serial number plate. This is located on the inside of the front frame between pan 1 and pan 2.

The software loaded into each programmable component is indicated by a label stuck onto each component: PLC, HMI, and VFD.

9.0 DIAGNOSTICS

The inputs and output of the PLC can be monitored using the HMI. Access the main screen using one of the orange buttons with the upward arrow.



From the main screen select the Troubleshooting screen. Green indicators show "on" states for all inputs X0-X7 and outputs Y0-Y5. The encoder counts can also be monitored here. There is also a button to force the solenoid "on."

PLC Inputs:		PLC Outputs:	
<input checked="" type="checkbox"/> X0: Length	<input checked="" type="checkbox"/> Y0: P1 Pulses		
<input checked="" type="checkbox"/> X1: Sensor In	<input checked="" type="checkbox"/> Y1: P2 Pulses		
<input checked="" type="checkbox"/> X2: Speed	<input checked="" type="checkbox"/> Y2: P1 Dir.		
<input checked="" type="checkbox"/> X3: P2 Home	<input checked="" type="checkbox"/> Y3: P2 Dir.		
<input checked="" type="checkbox"/> X4: Inv Fault	<input checked="" type="checkbox"/> Y4: Solenoid		
<input checked="" type="checkbox"/> X5: P1 Home	<input checked="" type="checkbox"/> Y5:		
<input checked="" type="checkbox"/> X6: Sensor Exit	Pump & Drives		
<input checked="" type="checkbox"/> X7: E-Stop			
FORCE SOLENOID ON ONE SEC:		<input checked="" type="checkbox"/> On	
High Speed Cntr (X0):	0		

10. CALIBRATION OF FOLD PANS

- 1.) Ensuring that #1 pan deflector does not rub the rolls:
 - A.) Either use the HALF FOLD IN PAN 2 only fold choice to send pan 1 into the deflect position or temporarily disconnect the 9 pin connector from the pan 1 to the frame and manually move pan 1 to the deflect position. Then reattach the connector. Make sure Pan 2 is not in deflect position.
 - B.) Turn the handwheel of the machine and listen and feel for any rubbing of the #1 pan's deflector on the rolls.
 - C.) If you do not feel or hear any rubbing then proceed to Step 2.
 - D.) If you do feel or hear any rubbing, then you will need to slightly adjust the position of the #1 pan deflector.
 - E.) Turn power off to the machine.
 - F.) Remove the #1 fold pan from the machine.
 - G.) On top of the paper stop assembly, there is a deflector pusher that has a curved surface that pushes a bar with a series of pins connected to it. This curved piece has 2 slots in it that allows for the position of the deflector to be adjusted. See Figure #3. This adjustment should only have to be adjusted a few thousandths of an inch from the factory setting. This is due to tolerance stackups within the machine.

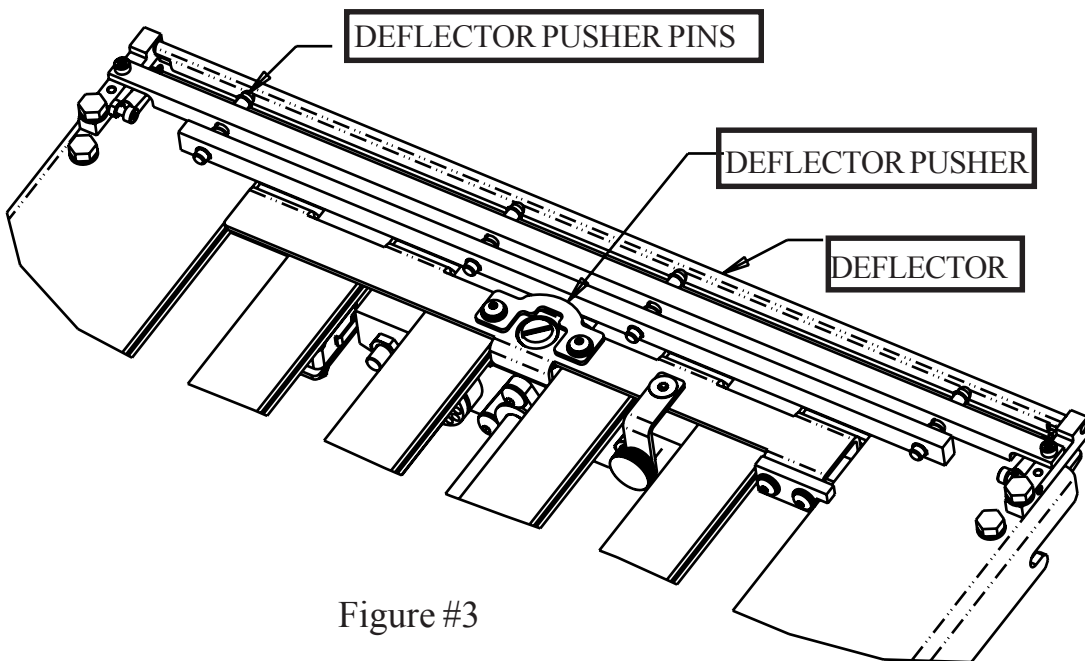
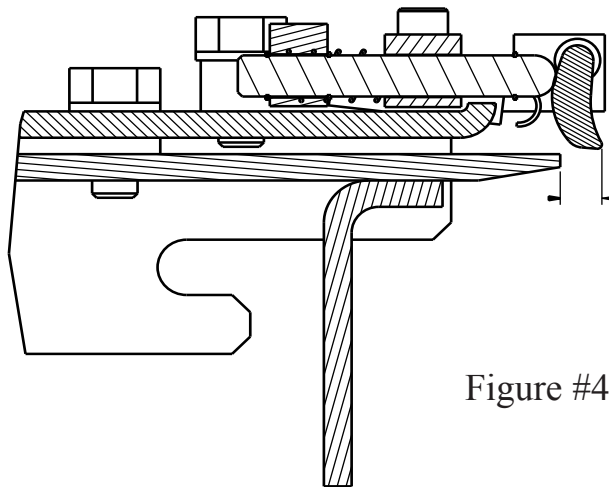

Figure #3

- H.) Loosen the 2 screws that are holding the deflector pusher in position on the paper stop assembly with a 2.5 allen wrench.
- I.) Move the deflector to the desired position to prevent the deflector from rubbing the rolls. This should only be moved enough to not allow the deflector to rub the rolls. This should be treated as a fine adjustment and not adjust the deflector to much as the paper may be able to enter the fold pan when the paper stop is in deflect, or if the deflector is moved to close to the rolls, the paper will not properly pass over the deflector and jam up in the fold rolls. See Figure #4 for the dimension used in the factory setting and also the maximum and minimum dimensions for this setting from lip of pan to outer edge of the deflector.



0.180"(4.58mm) FACTORY SETTING
 0.173"(4.40mm) MINIMUM SETTING
 0.185"(4.70mm) MAXIMUM SETTING

Figure #4

- J.) Retighten screws retaining the deflector pusher screws on to paper stop assembly. Be sure to not allow the deflector pusher to pivot as you are tightening these screws up, as this may cause the deflector to not be in the intended position.
- K.) Recheck the position of the deflector as described by the dimension called out in Step 1.I.
- L.) Reinstall the fold pan into the folder and connect the plug.
- M.) Turn the main power back on the machine.
- N.) After power up, press the current fold icon in the upper left hand corner of the production screen. Pick half fold P2 . Choose any paper length. Next will send both fold pans to home position and then reset their location according to the sheet length and type of fold currently selected. "At Fold Position" message indicates the movement is done.
- Note: The position of the deflector will need to be adjusted in this same manner any time the home position of the paper stop is changed by making adjustments to the paper stop screws. If this is not corrected each time these screws are adjusted, serious damage to the folder or fold pans may occur!

O.) Turn the handwheel of the machine and listen and feel for any rubbing of the #1 pan's deflector on the rolls. If there is not any rubbing of the deflector on the fold rolls proceed to Step 2.

2.) Ensure that #2 pan deflector does not rub the rolls:

- A.) Either use the HALF FOLD IN PAN 1 only fold choice to send pan 2 into the deflect position or temporarily disconnect the 9 pin connector from the pan 2 to the frame and manually move pan 2 to the deflect position. Then reattach the connector. Make sure Pan 1 is not in deflect position.
- B.) Turn the handwheel of the machine and listen and feel for any rubbing of the #2 pan's deflector on the rolls.
- C.) If you do not feel or hear any rubbing then proceed to Step 3.
- D.) If you do feel or hear any rubbing, then you will need to slightly adjust the position of the #2 pan deflector.
- E.) Turn power off to the machine.
- F.) Remove the #2 fold pan from the machine.
- G.) On top of the paper stop assembly, there is a deflector pusher that has a curved surface that pushes a bar with a series of pins connected to it. This curved piece has 2 slots in it that allows for the position of the deflector to be adjusted. See Figure #5. This adjustment should only have to be adjusted a few thousandths of an inch from the factory setting. This is due to tolerance stackups within the machine.

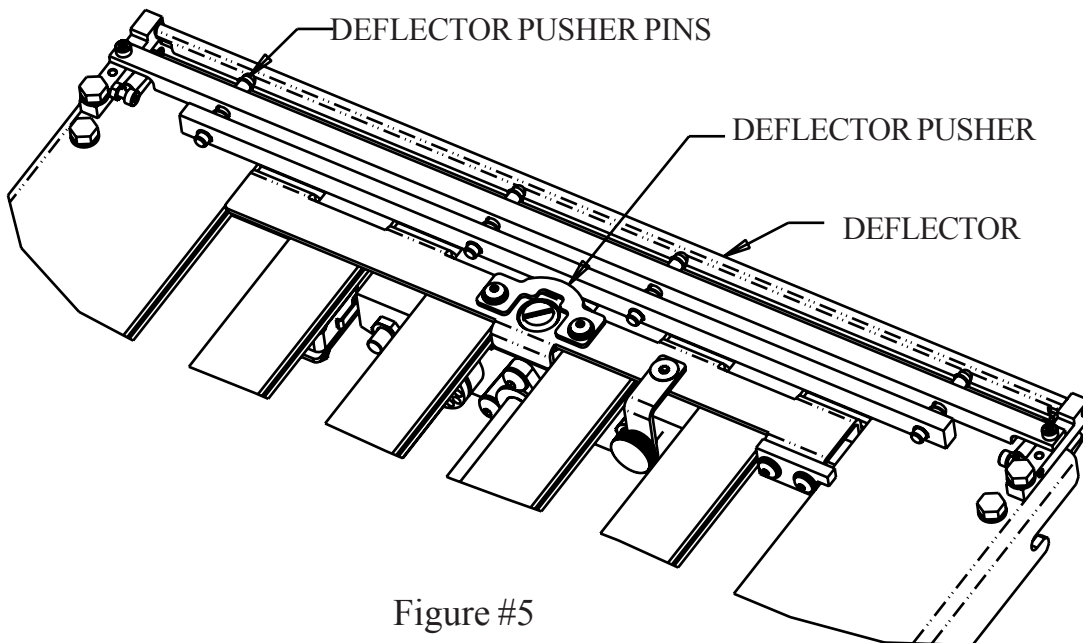
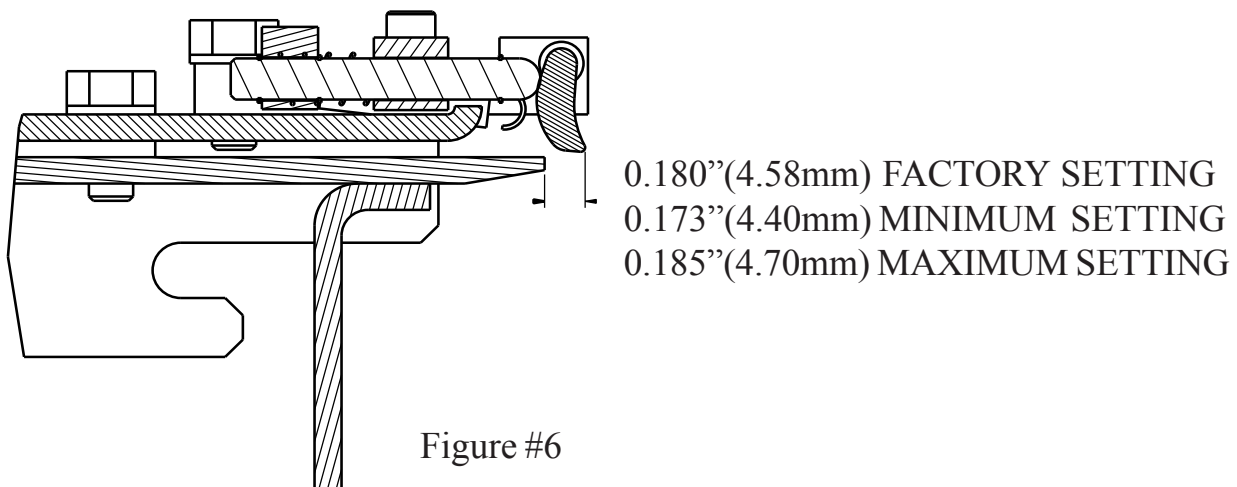

Figure #5

- H.) Loosen the 2 screws that are holding the deflector pusher in position on the paper stop assembly using a 2.5 allen wrench.
- I.) Move the deflector to the desired position to prevent the deflector from rubbing the rolls. This should only be moved enough to not allow the deflector to rub the rolls. This should be treated as a fine adjustment and not adjust the deflector to much as the paper may be able to enter the fold pan when the paper stop is in deflect, or if the deflector is moved to close to the rolls, the paper will not properly pass over the deflector and jam up in the fold rolls. See Figure #6 for the dimension used in the factory setting and also the maximum and minimum dimensions for this setting from the lip of the pan to the outer edge of the deflector.



- J.) Retighten screws retaining the deflector pusher screws on to paper stop assembly. Be sure to not allow the deflector pusher to pivot as you are tightening these screws up, as this may cause the deflector to not be in the intended position.
- K.) Recheck the position of the deflector as described by the dimension called out in Step #2.I.
- L.) Reinstall the fold pan into the folder and connect the plug.
- M.) Turn the main power back on the machine.
- N.) After power up, press the current fold icon in the upper left hand corner of the production screen. Pick half fold P1 . Choose any paper length. Next will send both new fold pans to home position and then reset their location according to the sheet length and type of fold currently selected. "At Fold Position" message indicates the movement is done.

Note: The position of the deflector will need to be adjusted in this same manner any time the home position of the paper stop is changed by making adjustments to the paper stop screws. If this is not corrected each time these screws are adjusted, serious damage to the folder or fold pans may occur!

- R.) Turn the handwheel of the machine and listen and feel for any rubbing of the #2 pan's deflector on the rolls. If there is not any rubbing of the deflector on the fold rolls proceed to Step #3.

Before proceeding with calibration of the fold pans, you must ensure that the sheets are being fed into the fold rolls squarely and that the sheets are hitting both paper stops of the new fold pans squarely. These new pans are calibrated with 8 1/2 x 11" 20# Bond copier paper. We use this stock since it is a common stock used in the tabletop folders.

- 3.) Ensure the paper is being fed into the fold rolls squarely:

- A.) Turn power off to the machine.
- B.) Remove the #1 fold pan.
- C.) Place a single sheet of paper into the feeder.
- D.) Move the non-operator side guide away from the sheet.
- E.) Manually feed the single sheet of paper by hand until it enters the nip of the fold rolls. Make sure that the sheet does not pull away from the operator side guide.
- F.) At this point you should be able to turn the handwheel and the sheet should become visible on the exit side of the Main and #1 fold rolls.
- G.) Compare the amount of paper now sticking out of the fold rolls on both the operator and non-operator sides.
 - If the amount is equal, then this means that the operator side guide of the feeder is feeding the sheet square to the fold rolls. Proceed to Step #3.N.
 - If the amount is not equal, then this means that the operator side guide of the feeder is not feeding the sheet square to the fold rolls and the operator side guide will need to be adjusted. Proceed to Step #3.H.

- H.) Loosen both front and rear thumb screws on the operator side guide.
 - I.) Push in and rotate the operator side guide skew adjust knob so that the side guide skews in the direction the sheet was being off square to the fold rolls.
 - J.) Now repeat steps #3.E - #3.G until the sheet is square to the fold rolls.
 - K.) Once the sheet is square to the fold rolls, hold the skew adjust knob in place and loosen the set screw for the operator side guide skew adjust knob.
 - L.) Now rotate the collar so that the slot in the collar slips over the nipple on the operator side guide skew adjust knob.
 - M.) Tighten set screw in the collar.
 - N.) Place a stack of 10 sheets into the feeder.
- O.) While holding the non-operator side of the stack of paper up, move the non-operator side guide so that the clear mylar plastic piece on the side guide is under the stack.
 - P.) Now adjust the non-operator side guide up to the stack of paper so that side guides do not allow the sheet to move side to side, but not so tight that the stack of paper is pinched by the side guides.
 - If the side guides are too loose, the side guides will not properly register the sheets and the folds will not be consistently square.
 - If the side guides are too tight, the side guides will prevent the sheets from being fed into the fold rolls.
 - Q.) Adjust the skew of the non-operator side guide, so that the side guide is parallel to the stack of paper.
 - If you have to adjust the skew of the non-operator side guide, follow the same procedure for adjusting the side guide skew adjust knob and collar on the operator side guide.
- 4.) Ensure the fold pan paper stops are square to the sheets:
 - A.) Using the Operator Control panel, select a half fold and enter proper sheet length.
 - B.) Handfeed a sheet into the nip of the fold rolls.
 - C.) Turn the handwheel until the sheet is just shy of touching the paper stop of the #1 fold pan.
 - D.) Adjust the skew of the #1 fold pan paper stop by turning the skew adjust thumb screw on the paper stop until it is parallel with the sheet.

- E.) Now turn the handwheel, and make sure that the edge of the paper hit at all points on the paper stop simultaneously.
- F.) Confirm the squareness of the side guides to the fold rolls and the sheet to the paper stop by turning the handwheel so that the sheet is folded. Sheet should be folded straight.
- G.) Using the Operator Control panel, select a double parallel fold and enter proper sheet length.
- H.) Handfeed a sheet into the nip of the fold rolls.
- C.) Turn the handwheel until the sheet is just shy of touching the paper stop of the #2 fold pan.
- D.) Adjust the skew of the #2 fold pan paper stop by turning the skew adjust thumb screw on the paper stop until it is parallel with the sheet.
- E.) Now turn the handwheel, and make sure that the edge of the paper hit at all points on the paper stop simultaneously.
- F.) Confirm the squareness of the side guides to the fold rolls and the sheet to the paper stop by turning the handwheel so that the sheet is folded. Sheet should be folded straight.

5.) Confirming the calibration of the #1 Fold Pan:

All though a set of calipers is not a requirement, they are recommended to measure the fold lengths of the sheet and to aid you in adjusting the position of the paper stop's home position. They will give you a more accurate measurement.

- A.) Load a stack of test paper into the feeder.
Note: Using stock that has print on it, or has been marked in some way will aid you in determining which edge is the leading edge of the sheet and which direction the paper stop needs to be adjusted.
- B.) Using the Operator Control Panel, select a half fold and enter the proper sheet length when prompted to do so.
- C.) Run a single test sheet. If the sheet is folded exactly in half then proceed to Step #6. If the sheet is not folded exactly in half, then proceed to Step #5.D.
- D.) Measure how much the folded length is off and note this for the adjustment later. Also note if the fold is to long or short.
- E.) Remove the #1 fold pan from the folder.

- F.) Run the paper stop to it's home position by rotating the paper stop lead screw by hand.
- G.) Carefully rotate the deflector up so that you may get the calipers or scale into the pan.
- H.) In the center of the fold pan, take a measurement from the edge of the lower half of the pan to the paper contact surface of the paper stop and note this. See Figure #7.

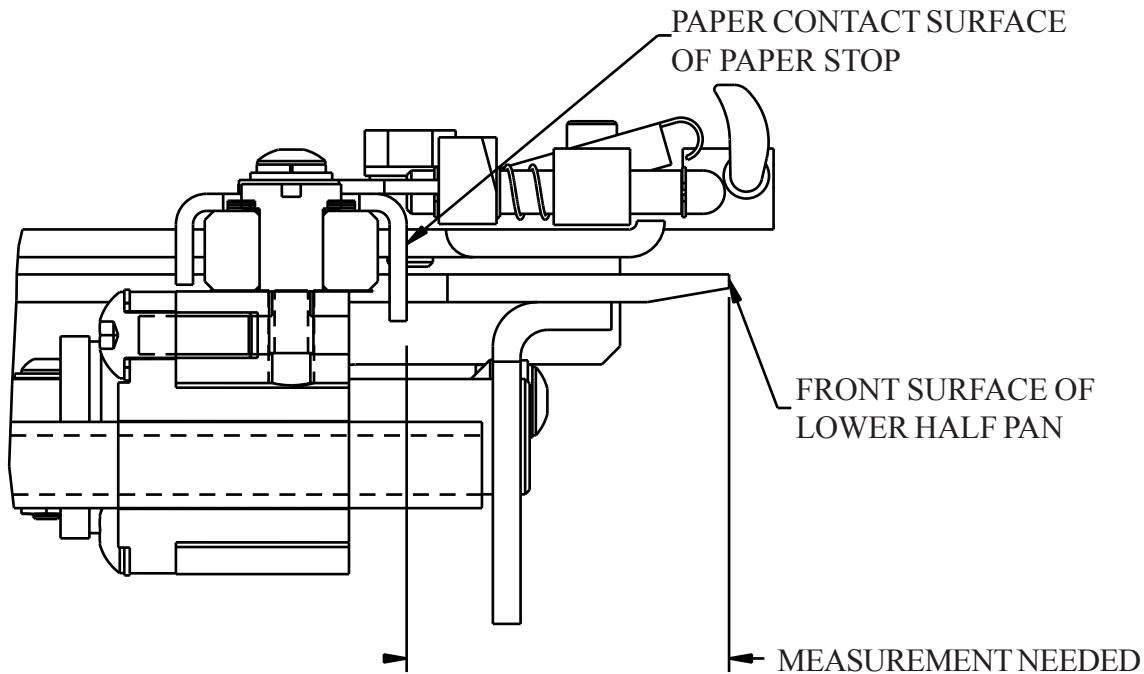

Figure #7

- I.) Using half of the measurement determined that the fold was off from being folded in half in Step #5.D will either be added to or subtracted from the measurement taken in Step #5.H.

-If the fold was to long, then half of the measurement taken in Step #5D will be subtracted from the measurement in Step #5.H. This will become the new measurement for the home position of the paper stop.

-If the fold was to short, then half of the measurement taken in Step #5D will be added to the measurement in Step #5.H. This will become the new measurement for the home position of the paper stop. Take note of this new home position for the paper stop.

- J.) Manually move the paper stop away from home position enough so that you may use a 4mm allen wrench in the flat head screws on the paper stop. These screws will be adjusted to position the paper stop correctly for the new home position. See Figure #8 on page 37.
- K.) Use a 10mm wrench to loosen up the nuts on the flat head screws. See Figure #8 on page 37.
- L.) Turn flat head screws further into the paper stop assembly.
- M.) Manually move the paper stop until the paper stop is in the correct position as determined in Step #5.I.
- N.) Run the flat head screws out of the paper stop assembly until the heads of the screws come in contact with the lower half pan brace. See Figure #8 on page 37.
- O.) Tighten the nuts on the flat head screws against the paper stop assembly.
- P.) Re-check that the paper stop is still positioned correctly by making sure it is at the dimension determined in Step #5.I.

HOME POSITION
SCREW JAM NUTS

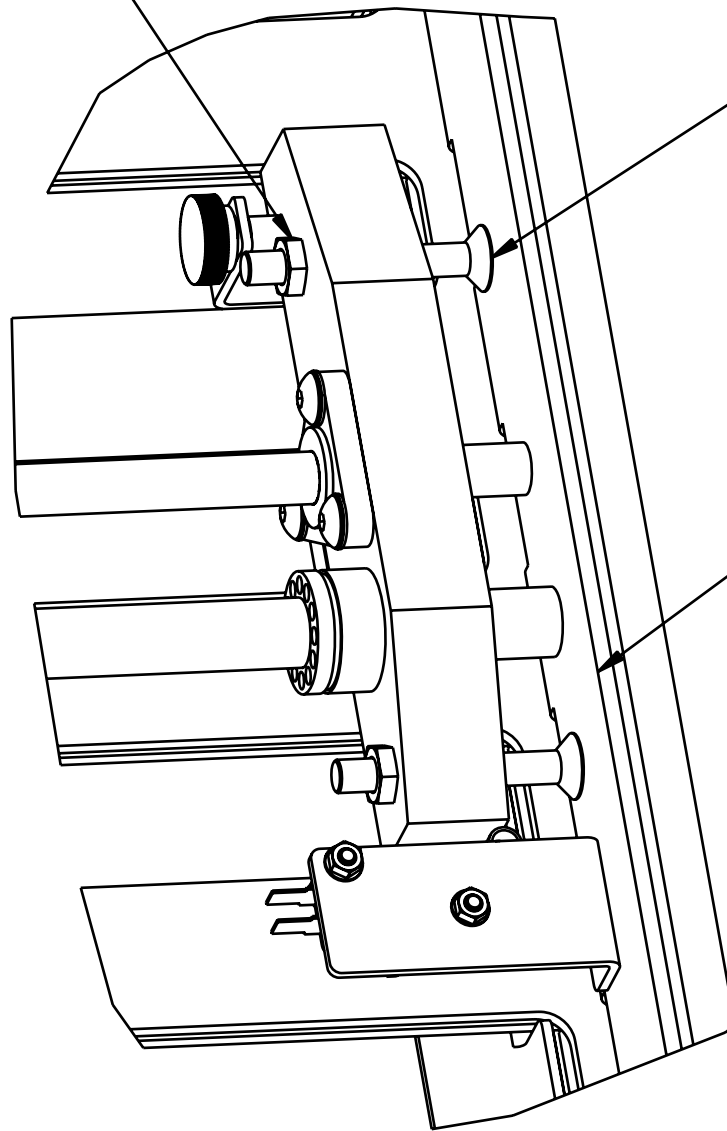

HOME
POSITION
SCREWS

LOWER
HALF
PAN
BRACE

Figure #8

- Q.) Loosen nuts holding the home position switch to it's bracket.
- R.) Manually move the paper stop assembly away from home position so that you have 0.25”(6.35mm) gap between the heads of the home position screws and the lower half pan brace. A 1/4” allen wrench may be used to aid in getting the proper distance.

Note: This dimension is critical. The software is programmed so that the paper stop must travel 0.25”(6.35mm) from the time when the home position switch is tripped until the paper stop reaches home. Any variation in this distance may cause the fold lengths to be off.

- S.) Move the home position switch so that the paper stop assembly trips at the position described in Step #5.R and tighten nuts holding switch.
- T.) The deflector pusher will now need to be reset as described in Steps #1.I - 1.O.
- U.) Place pan back into machine.
- V.) Turn power off and back on.
- W.) Choose to initialize the folder when prompted to do so by the Operator Panel Display.
Note: This must be done each time the paper stop's home position has been changed in order for proper functioning of the fold pan.
- X.) Select a half fold and enter the proper sheet length.
- Y.) Run a test sheet to check that the sheet is folded in half.
- Z.) If the sheet is folded exactly in half, then proceed to Step #6. If the sheet is not folded exactly in half, repeat Steps #5.D - 5.Y.

6.) Confirming the calibration of the #2 Fold Pan:

- A.) Using the Operator Panel, move the #1 fold pan into deflect, and move the #2 fold pan to the position that is half of the length of the test sheets you will be using to calibrate the fold pans. For example, if you are using 11” long paper, then set the #2 fold pan at 5.50”
- B.) Run a single test sheet. If the sheet is folded exactly in half then the machine is ready to run production. If the sheet is not folded exactly in half, then proceed to Step #6.C.
- C.) Measure how much the folded length is off and note this for the adjustment later. Also note if the fold is to long or short.
- D.) Remove the #2 fold pan from the folder.

- E.) Run the paper stop to it's home position by rotating the paper stop lead screw by hand.
- F.) Carefully rotate the deflector up so that you may get the calipers or scale into the pan.
- G.) In the center of the fold pan, take a measurement form the edge of the lower half of the pan to the paper contact surface of the paper stop. See Figure #9

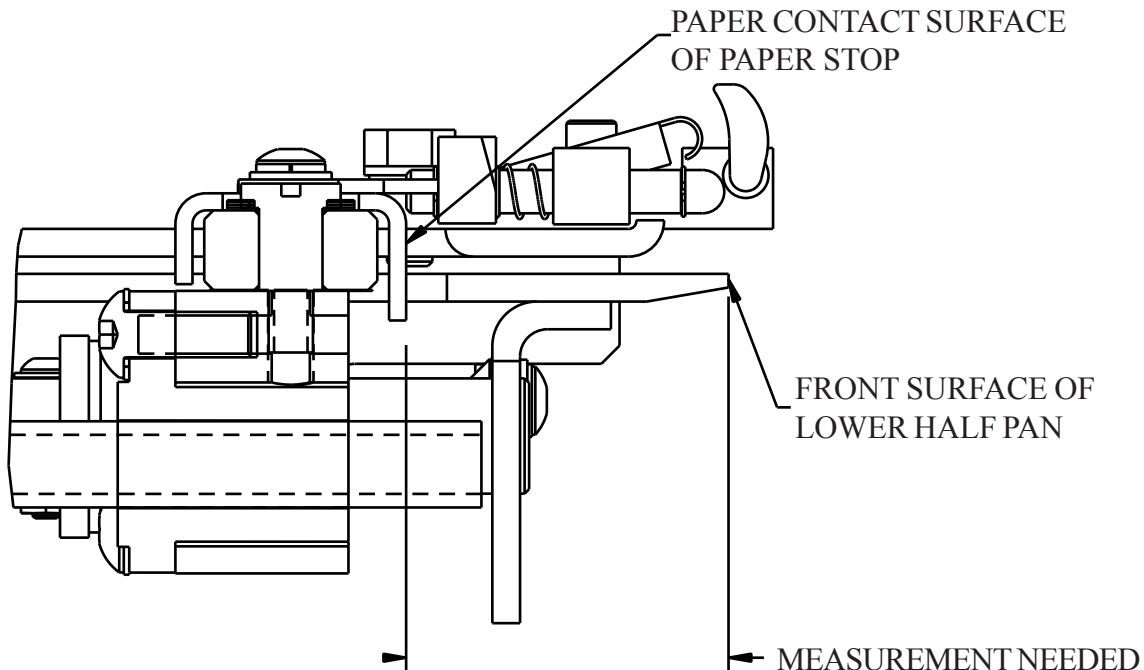

Figure #9

- H.) Using half of the measurement determined that the fold was off from being folded in half in Step #6.C will either be added to or subtracted from the measurement in Step #6.G.

-If the fold was to long, then half of the measurement taken in Step #6.C will be subtracted from the measurement in Step #6.G. This will become the new measurement for the home position of the paper stop.

-If the fold was to short, then half of the measurement taken in Step #6.C will be added to the measurement in Step #6.G. This will become the new measurement for the home position of the paper stop.

- I.) Manually move the paper stop away from home position enough so that you may use a 4mm allen wrench in the flat head screws on the paper stop. The screws will be adjusted to position the paper stop correctly for the new home position. See Figure #10.
- J.) Use a 10mm wrench to loosen up the nuts on the flat screws. See Figure #10.

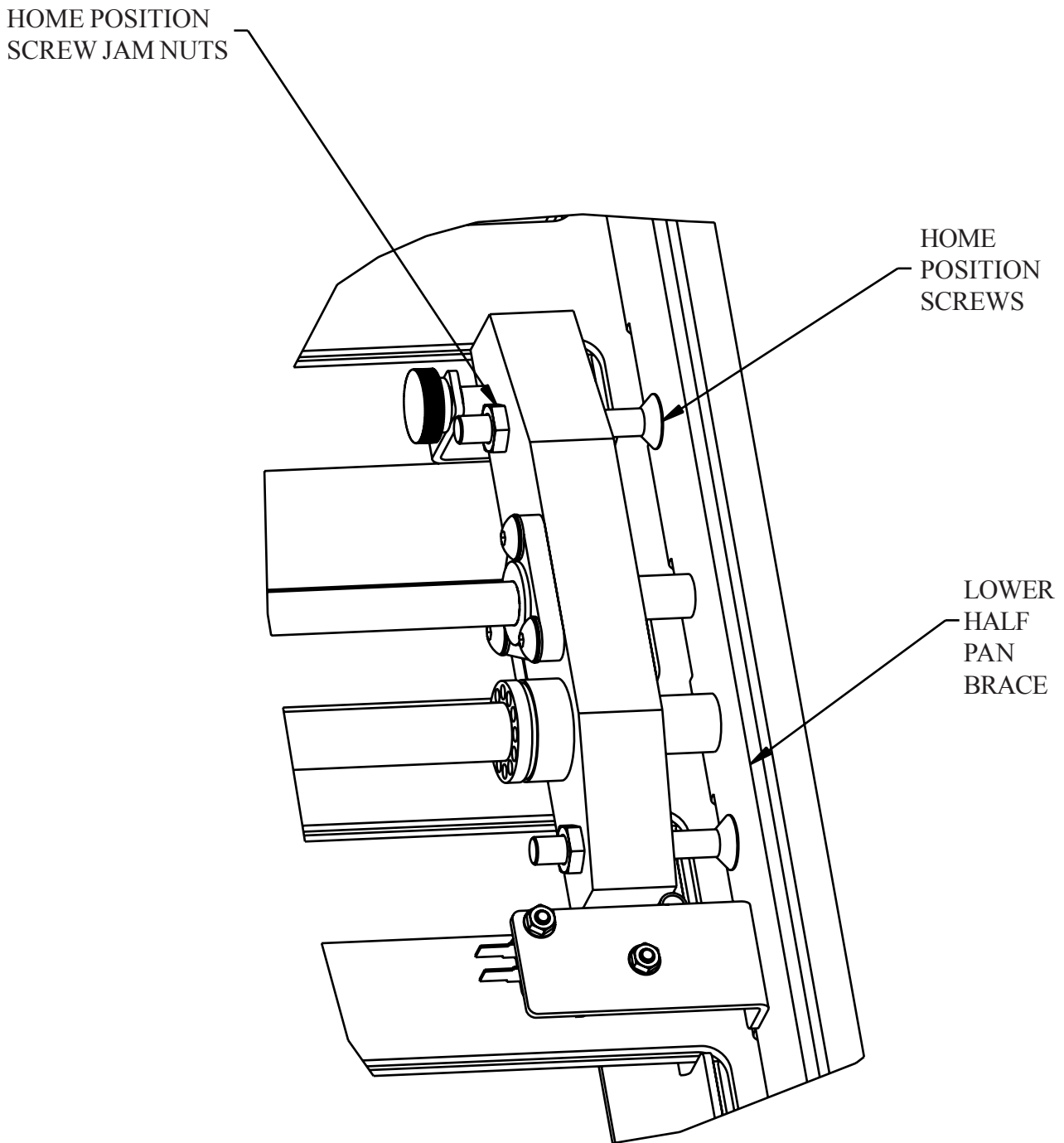

Figure #10

- K.) Turn flat head screws further into the paper stop assembly.
- L.) Manually move the paper stop until the paper stop is in the correct position as determined in Step #6.H.
- M.) Run the flat head screws out of the paper stop assembly until the heads of the screws come in contact with the lower half pan brace. See Figure #10.
- N.) Tighten the nuts on the flat head screws against the paper stop assembly.
- O.) Re-check that the paper stop is still positioned correctly by making sure it is at the dimension determined in Step #6.H.
- P.) Loosen nuts holding the home position switch to it's bracket.
- Q.) Manually move the paper stop assembly away from home position so that there is 0.25”(6.35mm) gap between the heads of the home position screws and the lower half pan brace. A 1/4” allen wrench may be used to aid in getting the proper distance.

Note: This dimension is critical. The software is programmed so that the paper stop must travel 0.25”(6.35mm) from the time when the home position switch is tripped until the paper stop reaches home. Any variation in this distance may cause the fold lengths to be off.

- R.) Move the home position switch so that the paper stop assembly trips at the position described in Step #5.R and tighten nuts holding switch.
- S.) The deflector pusher will now need to be reset as described in Steps #2.I - 2.O.
- T.) Place pan back into the machine.
- U.) Turn power off and back on.
- V.) Choose to initialize the folder when prompted to do so by the Operator Panel Display.
Note: This must be done each time the paper stop's home position has been changed in order for proper functioning of the fold pan.
- W.) Place the #1 fold pan into deflect and set the #2 fold pan at half of the sheet length you are running for this calibration procedure.
- X.) Run a test sheet to check that the sheet is folded exactly in half. If the sheet is folded exactly in half, the machine is now ready to run production. If the sheet is not folded exactly in half, then Steps #6.C - 6.X will need to be repeated.

TECHNICAL SPECIFICATIONS

BAUM 714XA

Maximum sheet size	14" x 25.5" [35.5 x 64.7 cm]
Maximum paper weight:	
Half Fold:	.0092"/0.234mm/ 218.22 gsm (.75" stack @ max)
Trifold	.0078"/0.198mm/176.83 gsm
Minimum sheet size	3" x 5" [7.6 x 12.7cm]
Maximum folder speed	30,000 sheets per hour (8.5"x11" sheets)
Maximum stack height	2" [50.8cm] @ .0078"/0.198mm/ 17.83 gsm or less
Minimum fold length	2" [50.8mm]
Fold plate depth	13.5" (34.3cm)
Electrical	110 Volt, 1 phase, 60 Hz, 20 Amperes 220 Volt, 1 phase, 50 Hz, 10 Amperes

See serial plate on folder

ACCESSORIES

In addition to the various folding, slitting, perforating and scoring functions the Baum 714XA can perform even more productive functions using the following accessories and more.

- Sound Guards

Contact your local Baumfolder Corporation sales representative for further information.

TROUBLESHOOTING

PROBLEM	CAUSE	REMEDY
Double sheets feed into sucker wheel.	Orange tab is set too high or vacuum adjustment too high.	Adjust orange tab "-" or turn first knob on delivery CCW.
Jam occurs at exit.	Paper is caught in the lower anti-static rope or pull out tires mispositioned.	Move magnets on frame so rope is not in the paper path or reposition pull out tires.
Batch count incorrect, too many sheets are being folded.	Double sheets fed into machine.	Adjust orange tab "-" or turn first knob on delivery CCW.
Batch count incorrect, too few sheet are folded.	Sensor "seeing" past the table and counting the same sheet twice.	Adjust pot on sensor CCW until second led lights only for paper on top of table.
Invertor Drive fault.	Ususally a bad paper jam.	Turn machine to "Off" using the bottom left switch. Allow power to discharge for at least 20 seconds and then restart the machine.
Paper runs in continuous mode but single sheet mode is selected.	Misalignment of the input sensor.	The input sensor's beam should aim straight through the hole in the feed table. Loosen the hardware securing the bar or twist bar slightly to re-aim into the hole.

INSTALLATION OF ANTISTATIC KIT:

1. Attach the ring terminal end of the antistatic kit to the existing stacker hardware:
 - A. Loosen the #4 nut closest to the unit that secures the black plastic enclosure to the inside of the stacker.
 - B. Next remove the now loose #4 black screw closest to the main unit.
 - C. Add a #4 external lock washer against the outside of the now open hole.
 - D. Stack the ring terminal on top of the #4 external lock washer.
 - E. Add a second #4 external lock washer on top of the ring terminal.
 - F. Now thread the removed #4 black screw back through the stack (including the black plastic enclosure.)
 - G. Finish by returning and tightening the #4 nut on the inside original position.



2. Attach the opposite end of the antistatic kit to the inside of the non-operator side frame using the magnet:
 - A. Be sure not to block the hole in the frame for the exit sensor (red).
 - B. Orient magnet so the cord is close to the rolls.
 - C. Be sure there is clearance between the gears and the cord.
 - D. Rotate the magnet so that the folded paper passes just above the cord.

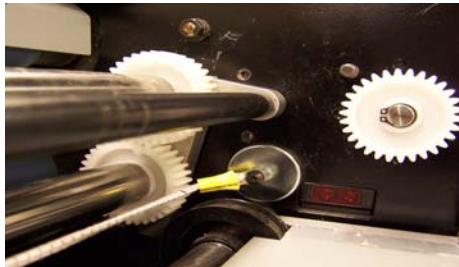

3. Attach the other magnet to the inside of the operator side frame:
 - A. Align the second magnet straight across from the first magnet.
 - B. Orient magnet so the cord is close to the rolls.
 - C. When changing paper weights the magnets may need to be rotated to stay just under the stream of folded paper.

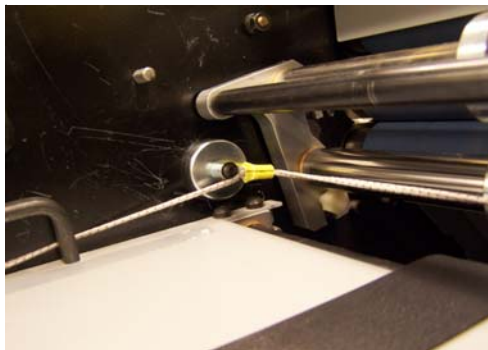

Baumfolder has authorized dealers located throughout the United States.

Call toll free, **1-800/543-6107** for parts or the number of your nearest authorized dealer.

BAUMFOLDER

CORPORATION

Quality Bindery Equipment Since 1917

1660 Campbell Road
Sidney, Ohio 45365-0728
Phone: 937/492-1281 or 800/543-6107
Fax: 800/452-0947
Internet: www.baumfolder.com
E-mail: baumfolder@baumfolder.com

