

# Geareducer<sup>®</sup> model 32.2

INSTALLATION - OPERATION - MAINTENANCE

Z0238997\_B ISSUED 09/2016

READ AND UNDERSTAND THIS MANUAL PRIOR TO OPERATING OR SERVICING THIS PRODUCT.

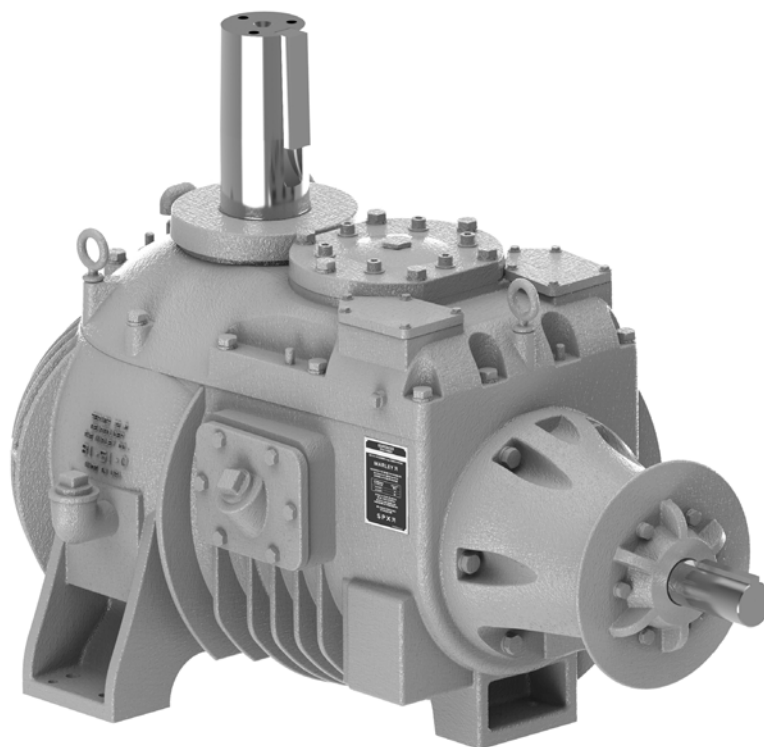

# operation and service

## Corrosion and Dry Start-Up Protection

Marley Geareducers utilize iron and steel materials, which if not maintained correctly, may degrade. While some external corrosion is acceptable, an internal lubrication film must be maintained at all times to protect the working components against corrosion and potential startup damage. The following information describes methods of operation and preventive measures to ensure suitability for long-term operation.

## Status Definitions

### Pre-Commission

Duration\* = Up to 4 months after receipt.

\*export shipment status duration is reduced by 1 month

This is the as-shipped condition, which contains a factory rust-proofing coating on the interior of the unit as well as a grease coating on the exposed shaft surfaces.

If the cooling tower is not ready for operation at the time of status expiration, steps must be taken to place the Geareducer into **Long-Term Storage or Downtime** status.

### Operational

This stage is initiated upon the first motor driven sequence. The Geareducer is now considered as being placed into regular service and operation.

### Idle

Duration = 2 to 4 weeks.

This stage is a suspension in operational status and lasts up to two 2 weeks. The duration may be doubled by completing a **Run Cycle**.

It is not recommended to extend the idle status more than once in any given sequence.

A common application is during a temporary outage

### Seasonal Shutdown

Duration = Up to 4 months after operational is suspended.

This stage may be considered an extended idle condition.

Requires additional preventive maintenance.

### Long-Term Storage or Downtime

Duration = Indefinite.

Requires long-term preventive measures.

### Run Cycle

Defined as full speed operation for a minimum of 30 minutes. This recoats all internal components and surfaces with lubricant and also helps to expel some moisture that may have accumulated from daily ambient condition cycling.

As shipped, a Marley Geareducer is protected internally against corrosion with machine enamel on un-machined parts and with rust-proofing oil and grease on machined surfaces. These coatings normally protect the Geareducer against corrosion for the duration of the **Pre-Commission** phase. Adding normal lubricant to the unit will dissolve the rust-proofing oil in the Geareducer sump. Provided it is added via the filler-neck or pumped in through the drain connection, this lubricant will not reduce the overall level of protection however, if the unit is operated for any amount of time, the **Pre-Commission** period is depleted and the unit is now considered to be in **Operational** status.

Check the Geareducer exterior yearly. Touch up with paint as required. Exposed pipe threads are coated to prevent corrosion. Touch up coating as required.

## Initial Operation

### Priming

Due to lack of control over facility operational readiness, site ambient conditions or storage practices, etc., it is recommended to supplement lubricant prior to initial operation. The same fill lubricant should be poured or pumped into the port above the interstage shaft. Remove pipe plug in center of Interstage Bearing Cap to expose port. Refer to **Figure 1**. If additional oil is being used, an amount of 1 to 1 1/2 quarts should be used. If the lubricant is being pumped from the sump bulk volume, at least 1 quart **should** be transferred. In either case, this priming step should be performed within 5 days of initial operation. If a delay occurs and the 5 day duration is exceeded, repeat the process. In either case, this priming step should be performed **while rotating the gear train by hand** and within 5 days of initial operation.

**Warning** – Operating the Geareducer at an oil level other than between the Add and Full levels may damage the unit and possibly mating equipment. This could also escalate to a safety concern for nearby personnel.

The Geareducer must be filled with oil to the Full oil level mark on the Geareducer case before it is placed in operation. If the unit is being taken out of **Long-Term Storage or Downtime**, the oil should be drained down to the Full operating level. If drain-down occurs within 5 days of the initial startup, the above priming sequence may be skipped. See **Service and Lubrication** section for oil filling instructions.

Geareducers supplied with new cooling towers include oil for the initial filling and in some cases, will also ship with an additional amount required to place the unit into **Long-Term Storage or Downtime** status. Normally, oil is not furnished with Geareducers supplied as a spare or on replacement orders. Before operating the mechanical equipment, check to be sure the oil level is at the Full mark at the Geareducer and that the external gauge placard Full mark corresponds with the Full level in the Geareducer. Check oil lines to be sure there are no leaks.

## operation and service

The Geareducer vent or vent line must be checked for blockage to prevent failure of pinion shaft oil seal—clean when necessary.

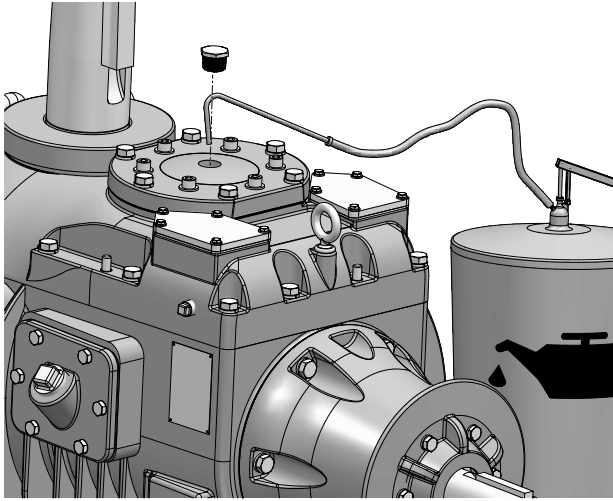

**Figure 1** Priming Interstage Shaft

Check all gasketed joints for oil seepage. Tighten cap screws and flange bolting if necessary.

The Geareducer must be installed level and properly aligned with the driveshaft and motor shaft. Refer to the ***Driveshaft User Manual***.

It is recommended to operate the Geareducer for no less than 30 minutes in any given run sequence. It is acceptable to ignore this when “bumping” the motor for confirmation of the correct direction of rotation.

### **Seasonal Shutdown** up to 4 months

At start of shutdown period, perform a **Run Cycle** and change the oil. See section on **Service and Lubrication**.

Every 2 weeks check the oil level and perform a **Run Cycle**.

Once each month drain any water condensation from the lowest point of the Geareducer and its oil system. Check the oil level and add oil if necessary. Perform a **Run Cycle**.

To put back into operation, drain water condensation from the lowest point of the Geareducer and its oil system and check oil level. Add oil if necessary.

### **Long-Term Storage or Downtime** indefinite duration

If unit has been in an operational state, perform a **Run Cycle** and drain the oil including volume in the oil line, if equipped. If in storage, unit does not need to be operated.

Fabricate and install an overflow reservoir system and fill unit entirely full of oil.

**Maintenance Cycle** If unit is stored outdoors, drain condensate monthly and top off oil as necessary. If unit is stored indoors, but not climate controlled, maintenance cycle may be extended to 3 months. If stored in climate controlled space, cycle may be extended to once per year.

See *Marley User Manual Z0238848 “Cooling Tower Downtime Instructions”* and *Marley Drawing Z0544916 “Marley Geareducer Reservoir System”* for further information.

### **Inspection Of Internal Parts**

Remove the inspection cover plate from the side of the Geareducer case at each oil change. Check inside of Geareducer for cleanliness of case and internal parts. If any sludge is present, flush inside of Geareducer and connecting oil line.

Also at this time, observe the contact pattern of the gear teeth to see if they appear as illustrated in **Detail A** and **B**. If incorrect gear tooth pattern should occur, refer to *Marley Field Repair Manual* for Series 32.2 Geareducer.

### **Repair and Overhaul**

Geareducers can be repaired in the field, however, major repairs require the use of a fully equipped machine shop. If field repair or overhaul is preferred, refer to Geareducer Parts Manual sheets for parts required. Field repair instructions are available from Marley on request. Contact the Marley sales office or Marley representative in your area for information.

# operation and service

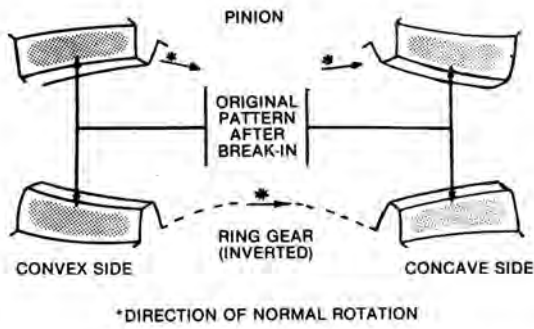

CORRECT PINION & RING GEAR TOOTH BEARING

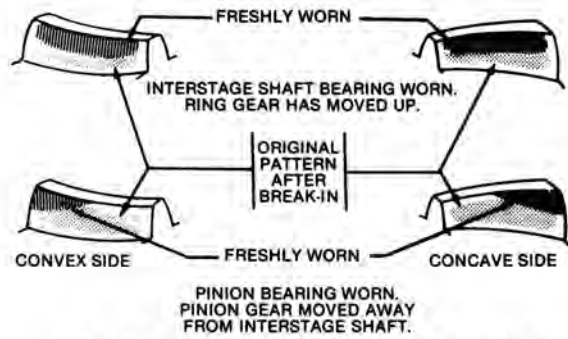

INCORRECT RING GEAR TOOTH BEARING

Detail A Spiral Bevel Gear Tooth Pattern

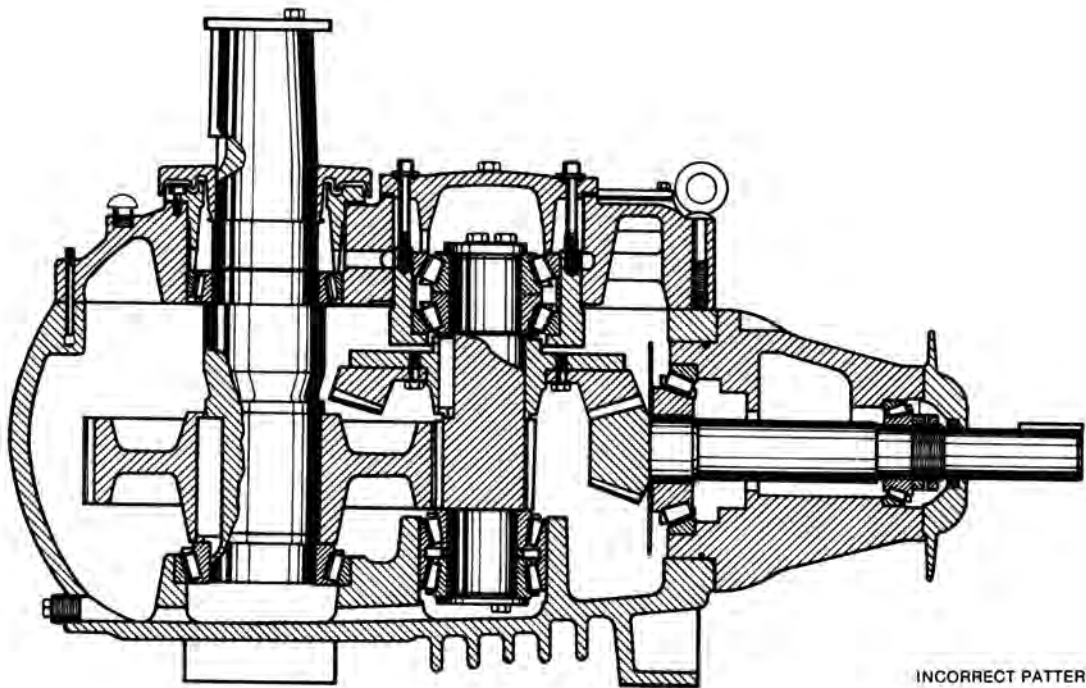

INCORRECT PATTERN

CHECK TOP INTERSTAGE BEARING AND BOTTOM FAN SHAFT BEARING. IF ONE OR BOTH ARE WORN, REPLACE.

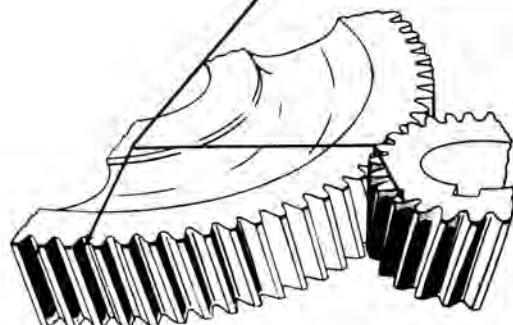
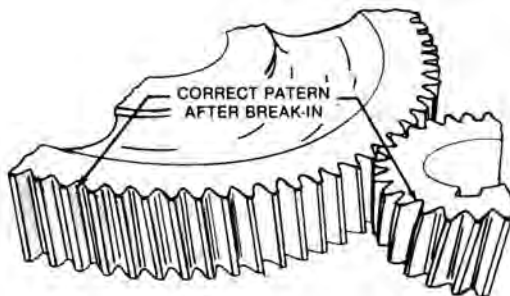

Detail B Helical Gear Tooth Pattern

# operation and service

## Service and Lubrication

The horizontal part of the oil gauge and drain line must be level or slightly lower at the sight glass than it is at the Geareducer. The oil capacity of Series 32 Geareducers is 9 gallons. The oil capacity of the optional oil filter is one additional gallon. Connecting oil gauge and drain lines require approximately one gallon of oil. Refer to **Table I** for suggested lubricants.

Fill the Geareducer and gauge and drain line system with oil, using one of the following procedures:

Recommended procedure:

1. Pour oil through fill hole in Geareducer inspection cover until it reaches height of "full" mark in the Geareducer case and at the sight glass. See **Figures 2** and **4**. Reinstall pipe plug in the fill hole.
2. Start fan drive. Run for one minute.
3. Stop the Geareducer. Allow ten minutes for oil level to stabilize and recheck oil level at Geareducer.
4. If necessary, repeat steps 2 and 3 until stabilized oil level is at the proper height.
5. Check placard location. "Full" mark on placard must be at same elevation as "full" mark on Geareducer.

Alternate procedure:

If the cooling tower has an external oil gauge and drain line equipped with three-way valve below sight glass the following alternate procedure may be used:

1. Remove pipe plug. Turn valve control stem clockwise to open drain. Collect used oil in an appropriate container.
2. With Geareducer drained, the three-way valve turned clockwise, and the pipe plug removed, connect fill source, either a street ell and stand pipe of sufficient length to extend above top of the sight glass or a hose to a pump, to the three-way valve.

Pour oil through a funnel and stand pipe, or pump oil through the hose. Check oil level occasionally by turning the valve control stem counterclockwise and allowing the oil level in the sight glass to stabilize. Continue filling until full level mark is reached.

3. With the oil level at the full mark turn the valve control stem counterclockwise to close the drain and open the valve to the sight glass. Remove the oil filling line and reinstall pipe plug in the three-way valve.

**Regardless of the procedure used, the Geareducer must be filled to the full mark on the Geareducer.**

Maintenance of the Geareducer should be scheduled as follows:

**MONTHLY:** Check oil level at least once a week using the following procedure:

Stop the Geareducer. Allow ten minutes for oil level to stabilize and check oil level at sight glass. If needed, add oil to Geareducer. If oil is added, repeat steps 2 and 3 of recommended procedure until stabilized oil level is at the proper height.

**SEMI-ANNUALLY:** Change oil at least every 6 month or 3,000 hours of operation. Refer to recommended oil fill procedure. The oil filter cartridge should be replaced at every oil change.

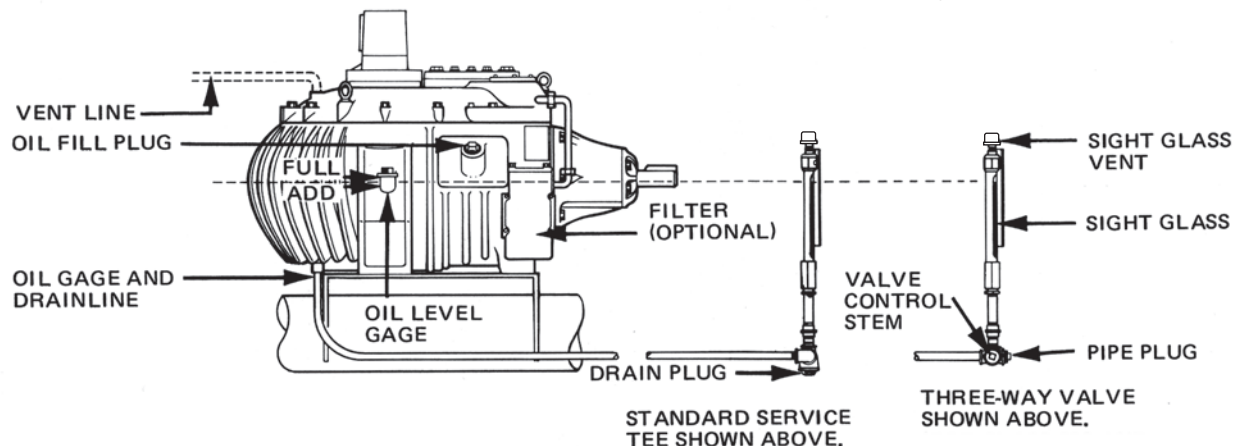

**Figure 2** Oil Gauge and Drain Line (Series 36 Geareducer is illustrated)

# operation and service

## Oil Filter Service

To replace the filter cartridge, first drain the oil from the Geareducer case, then remove the drain plug from the oil filter case. See **Figure 3**.

1. Remove the four cap screws attaching the oil filter case cap, and remove cap.
2. Remove and discard oil filter cartridge. Retain cartridge retainer washer and nut for re-installation.
3. Clean gasket material from filter case and cap.
4. Clean inside of filter case, cap and filter hardware.
5. Install new filter cartridge. Reinstall cartridge retainer washer and nut. Install new cap gasket and reinstall filter case cap.
6. Coat drain plug threads with Permatex Pipe Joint Compound No. 51 or equal. Reinstall drain plug and tighten securely.
7. After refilling unit with oil and operating unit, check all gasketed joints for oil seepage. Tighten flange bolts if necessary.

Check the oil level placard location each time the oil is changed. The "full" mark on the placard must be at the same elevation as the "full" arrow on the side of the Geareducer case—see **Figures 2 and 4**.

Sight glass vent must be kept open. Inspect at each oil change and clean when necessary. Inspect internal parts and inside of Geareducer case at each oil change—see section on inspection of internal parts. Use oil recommended in Table 1 for the proper atmospheric temperature range.

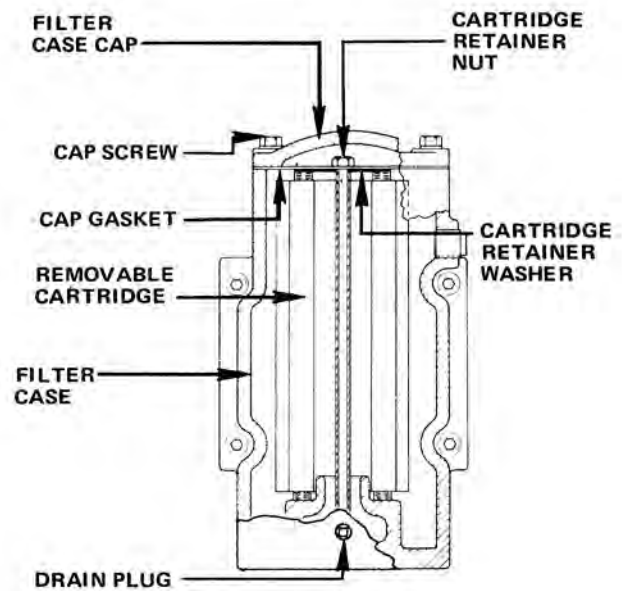

**Figure 3** Cross section of oil filter

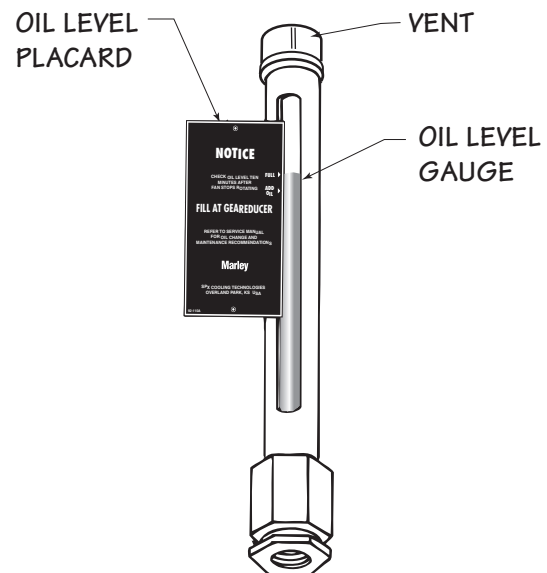

**Figure 4** Sight glass gauge assembly

## operation and service

If lubricants other than Marley factory lubricants are used, they must not contain any additives (such as detergents or EP additives) which are adversely affected by moisture and could reduce the service life of the Geareducer. The responsibility for use of lubricants other than Marley factory lubricants rests with the customer/owner and the lubricant supplier.

Seasonal temperature changes may require one viscosity of oil for summer operation and another for winter operation. Refer to the tables below for the seasonal selection information.

Winter or Summer	Severe Duty/High Temperature
Air Temperature at Geareducer	
Below 110°F (43°C)	Above 110°F (43°C)
ISO 150	ISO 220

**Table 1**

Maintenance Service	Monthly	Semi-annually	Seasonal Startup or Annually
<b>Geareducer Drive:</b>			
Inspect and tighten all fasteners including oil plug		<b>x</b>	<b>x</b>
Check for and repair oil leaks	<b>x</b>	<b>x</b>	<b>x</b>
Check oil level	<b>x</b>	<b>R</b>	<b>x</b>
Change oil		<b>R</b>	<b>R</b>
Make sure vent is open		<b>x</b>	<b>x</b>
Check driveshaft alignment			<b>x</b>
Inspect and tighten driveshaft fasteners			<b>x</b>
Check driveshaft bushing / flex elements for unusual wear			<b>x</b>
<b>Lube Lines (if equipped)</b>			
Check for oil leaks in hoses and fittings	<b>x</b>	<b>R</b>	<b>x</b>

**R** – Refer to instructions within this manual

**Note:** It is recommended at least weekly, that the general operation and condition be observed. Pay particular attention to any changes in sound or vibration that may signify a need for closer inspection.

# Geareducer 32.2

USER MANUAL

---

**SPX COOLING TECHNOLOGIES, INC.**

7401 WEST 129 STREET  
OVERLAND PARK, KS 66213 USA  
913 664 7400 | [spxcooling@spx.com](mailto:spxcooling@spx.com)  
[spxcooling.com](http://spxcooling.com)

Z0238997\_B (M92-1436B) | ISSUED 09/2016  
COPYRIGHT © 2016 SPX CORPORATION

In the interest of technological progress, all products are subject to design  
and/or material change without notice.

