

# SPECIFICATIONS

## CINCINNATI RIGID SHAPERS

Machine / Stroke Service		16"	16"	20"	20"	20"	24"	24"	28"	32"	36"
		Utility	Heavy	Utility	Std.	Heavy	Std.	Heavy	Heavy	Heavy	Heavy
Stroke, Actual Length		17"	17"	21"	21"	21"	25"	25"	29"	33"	37"
Strokes Per Minute		15 to 200	12 to 157	15 to 200	12 to 157	10 to 129	10 to 129	9 to 119	9 to 119	8 to 102	8 to 102
Cutting Speeds		8	8	8	8	8	8	8	8	8	8
Feed to Head		7 1/2"	7 1/2"	7 1/2"	7 1/2"	7 1/2"	7 1/2"	9 1/2"	9 1/2"	9 1/2"	9 1/2"
Cross Feeds, Number		11	11	11	11	11	11	11	11	11	11
Cross Feeds, Range		.010 to .170	.010 to .170	.010 to .170	.010 to .170	.010 to .170	.010 to .170	.010 to .170	.010 to .170	.010 to .170	.010 to .170
Table Travel, Horizontal		24"	24"	24"	24"	24"	24"	30 1/2"	30 1/2"	30 1/2"	30 1/2"
Table Travel, Vertical		13"	13"	13"	13"	13"	13"	13"	13"	13"	13"
Plain Table to Ram, Maximum		17 1/2"	17 1/2"	17 1/2"	17 1/2"	17 1/2"	17 1/2"	17 1/2"	17 1/2"	18"	18"
Table Top, Plain Table		14"x16"	14"x16"	14"x20"	14"x20"	14"x20"	14"x24"	16"x24"	16"x28"	16"x32"	16"x36"
Universal Table To Ram, Maximum	Tilting Face	17 1/8"	17 1/8"	17 1/8"	17 1/8"	17 1/8"	17 1/8"	17 1/8"	17 1/8"	17 1/8"	17 1/8"
	Solid Face	17 3/8"	17 3/8"	17 3/8"	17 3/8"	17 3/8"	17 3/8"	17 1/2"	17 1/2"	18"	18"
Universal Table Size	Tilting Face	13 1/4"x15"	13 1/4"x15"	13 1/4"x15"	13 1/4"x15"	13 1/4"x15"	13 1/4"x15"	15"x18 1/4"	15"x18 1/4"	15"x26 3/4"	15"x26 3/4"
	Solid Face	13 1/4"x16"	13 1/4"x16"	13 1/4"x16"	13 1/4"x16"	13 1/4"x16"	13 1/4"x16"	16"x20 1/2"	16"x20 1/2"	16"x28 1/2"	16"x28 1/2"
Tools, Largest Size		7/8"x1 1/2"	7/8"x1 1/2"	7/8"x1 1/2"	7/8"x1 1/2"	7/8"x1 1/2"	7/8"x1 1/2"	1"x2"	1"x2"	1"x2"	1"x2"
Vise, Single or Double Screw	Jaw Size, Double	2 1/2"x12"	2 1/2"x12"	2 1/2"x12"	2 1/2"x12"	2 1/2"x12"	2 1/2"x12"	3"x15"	3"x15"	3"x15"	3"x15"
	Jaw Size, Single	3"x15"	3"x15"	3"x15"	3"x15"	3"x15"	3"x15"	3 1/2"x17 1/2"	3 1/2"x17 1/2"	3 1/2"x17 1/2"	3 1/2"x17 1/2"
	Jaws, Open	13"	13"	13"	13"	13"	13"	15"	15"	15"	15"
	Body, Height	4 3/4"	4 3/4"	4 3/4"	4 3/4"	4 3/4"	4 3/4"	5"	5"	5"	5"
Drive Motor	H.P.	5	5	5	5	5 or 7 1/2	7 1/2	10	10	10	10 to 15
	Speed, R.P.M.	1800	1800	1800	1800	1800	1800	1800	1800	1800	1800
Approx. Shipping Wt.	Plain Table	5400	5760	5500	5880	6600	6720	8760	8880	10320	10560
	Universal Table	5700	6060	5800	6180	6900	7020	9210	9330	10870	11110

SECTION I  
IDENTIFICATION

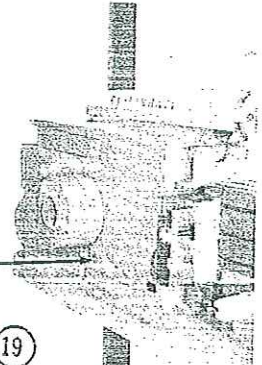
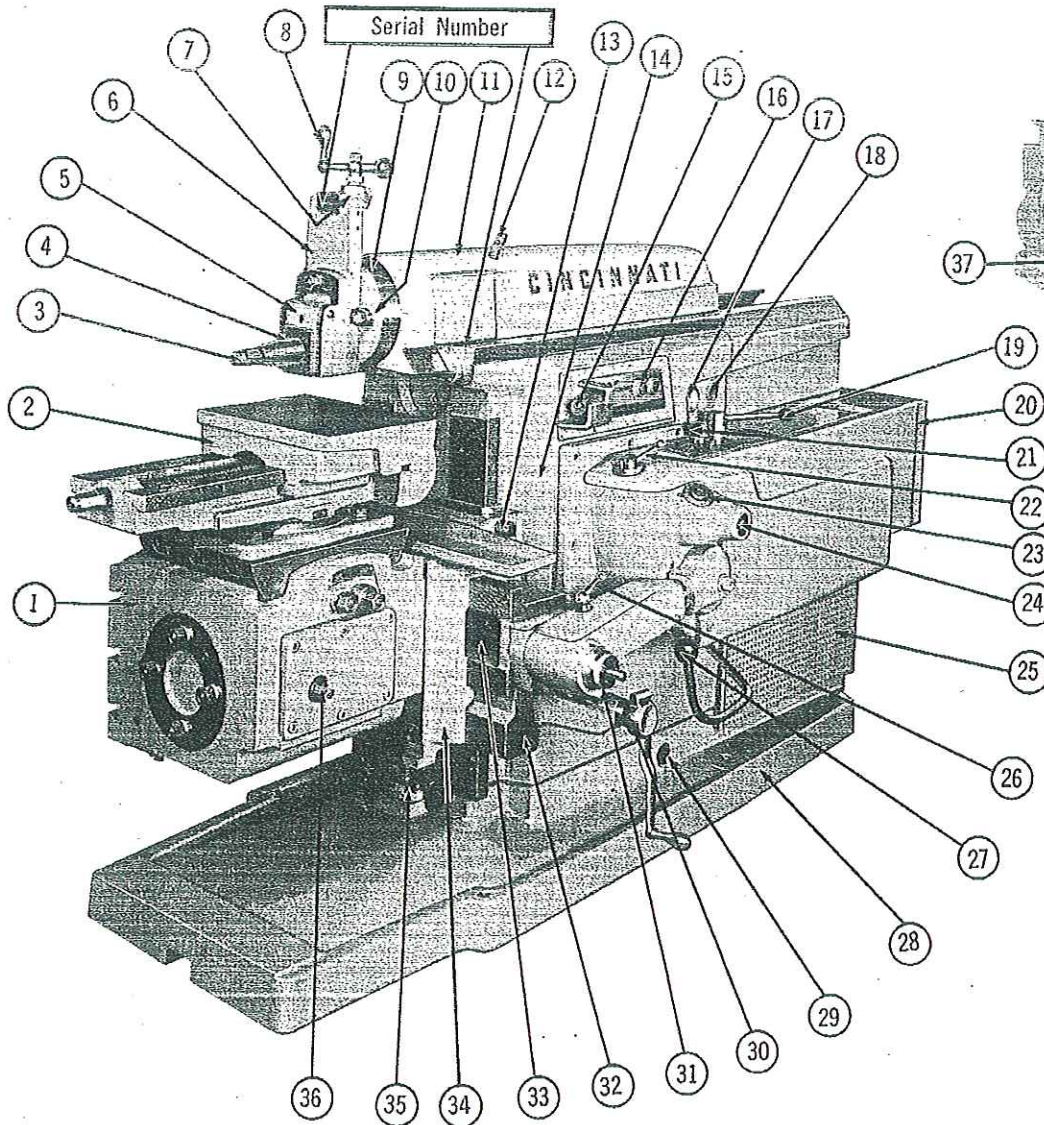

RIGID S  
WITH PLAI

RIGID SHAPER WITH UNIVERSAL TABLE

- |                               |                                       |                                   |
|-------------------------------|---------------------------------------|-----------------------------------|
| 1. Universal Table            | 15. Electric Clutch and Brake Control | 27. Power Rapid Travel            |
| 2. Vise (Single Screw)        | 16. Start And Stop Buttons            | 28. Shaper Base                   |
| 3. Tool Post                  | 17. Oil Pressure Gage                 | 29. Oil Sight Gage                |
| 4. Clapper                    | 18. Lifting Hole Cover                | 30. Rail Elevating Manual Control |
| 5. Clapper Box                | 19. Gear Shifter Lever                | 31. Cross Feed Manual             |
| 6. Tool Slide                 | 20. Electrical Control Box            | 32. Cross Rail                    |
| 7. Feed Screw Dial            | 21. Back Gear Selector Lever          | 33. Cross Feed Stop               |
| 8. Ball Crank                 | 22. Power Cross Feed Selector         | 34. Apron                         |
| 9. Graduated Head Travel      | 23. Stroke Indicator Dial             | 35. Elevating Screw               |
| 10. Tool Slide Clamping Screw |                                       | 36. Auto Feed Stop                |

# OPERATION AND MAINTENANCE OF CINCINNATI RIGID SHAPERS

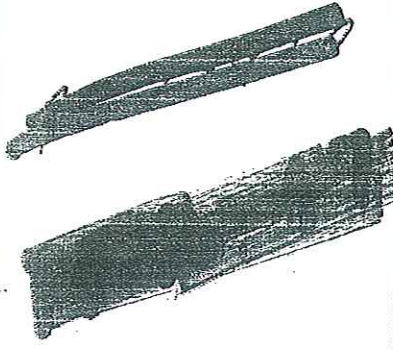

2-130

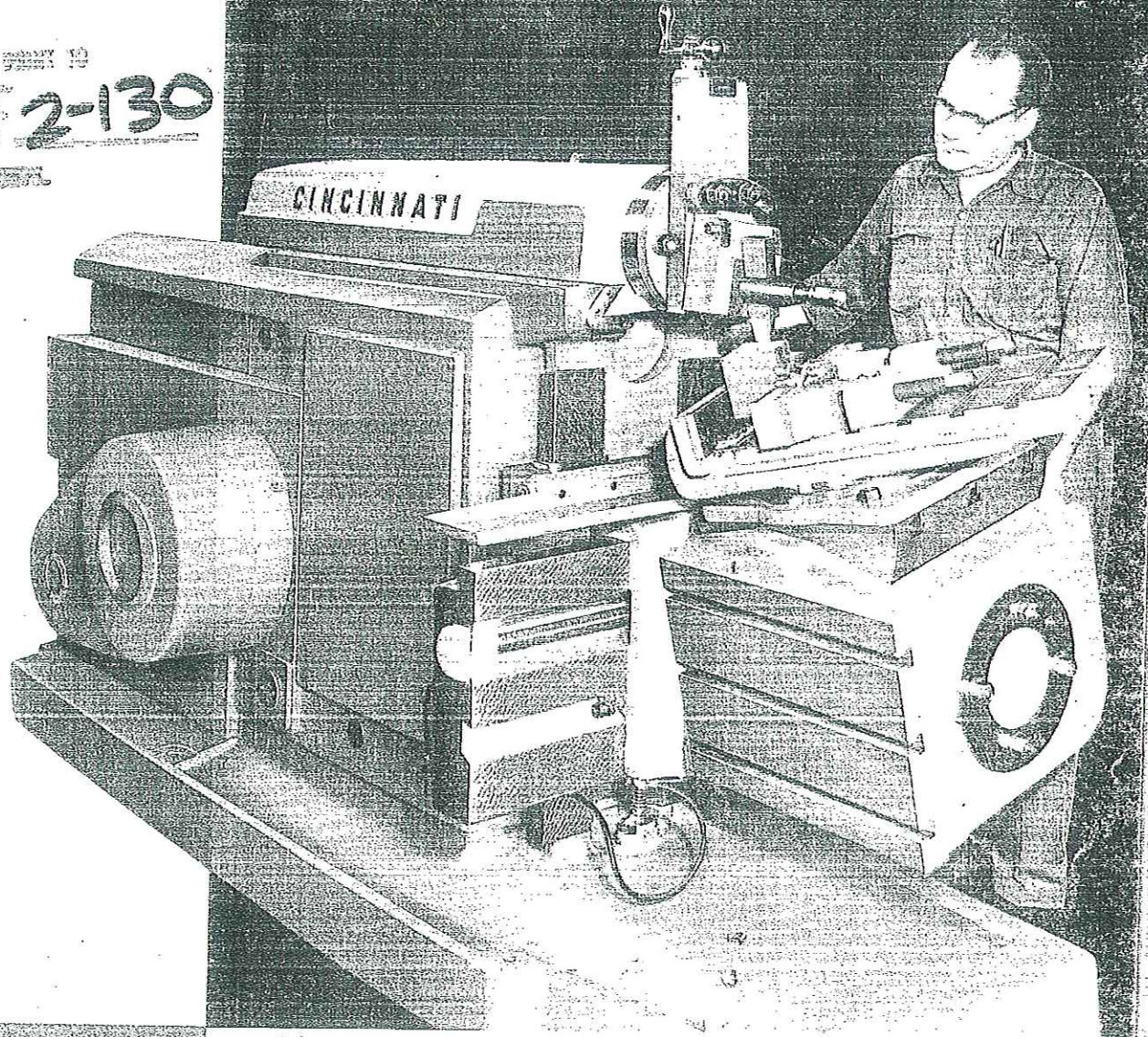

THE  
CINCINNATI

