

INDUSTRIAL DIESEL ENGINE

KUBOTA BG-SERIES (3-cylinder)

D1105-BG

RATED POWER

9.5 kW/1500 rpm



FEATURES with BENEFITS

Emissions

- Kubota BG engines are designed for generator applications to be operated at 1500 rpm or 1800 rpm only. The D1105-BG represents the smallest displacement for such low speed applications with superior reliability and durability. The special governor integrated into a highly rigid crankcase combines best performance at minimum noise levels.

Cleaner Exhaust Engines

- One of Kubota's major commitments has always been the development of a cleaner exhaust engine. Kubota was the first engine manufacturer to pass the U.S. CARB ULGE emission regulations for engines under 19 kW. Kubota produced engines that have been certified, or are now currently in compliance with all emission regulations around the world.

E-TVCS (Three Vortex Combustion System)

- Kubota's highly efficient E-TVCS System (Three Vortex Combustion System), located in a specially designed piston with a valve recess and a fanshaped concave, produces an ideal air/fuel mixture by creating three vortexes in the combustion chamber. This results in better cross flow of air and exhaust gas, lower air intake temperature and improved combustion efficiency.

Super Glow System

- The Super Glow System, not necessary in temperatures above 5°C, comes as standard equipment to start the engine in cold temperatures. For example, at -20°C (-4°F), the engine will start only 10 seconds of preheating time.

GENERAL SPECIFICATION

Model		D1105-BG
Emission Regulation		no EG regulation
Type		Vertical 4-cycle Liquid Cooled Diesel
Number of Cylinders		3
Bore	mm (in)	78.0 (3.07)
Stroke	mm (in)	78.4 (3.09)
Displacement	L (cu.in)	1.123 (68.53)
Combustion System		Indirect Injection
Intake System		Naturally Aspirated
Maximum Speed	rpm	1500
Output: Stand-by ISO 3046 IC15N	kW	9.5
	hp	12.8
	ps	13.0
Output: Continuous ISO 3046 IC15N	kW	8.4
	hp	11.3
	ps	11.5
Direction of Rotation		Counterclockwise viewed on Flywheel
Oil Pan Capacity	L (gal)	5.1 (1.35)
Starter Capacity	V-kW	12-1.4
Alternator Capacity	V-A	12-30
Length	mm (in)	551.3 (21.7)
Width	mm (in)	396.0 (15.59)
Height (1)	mm (in)	602.0 (23.7)
Height (2)	mm (in)	227.6 (8.96)
Dry Weight	kg (lb)	109.0 (240.3)

*Specification is subject to change without notice.

*Dry weight is according to Kubota's standard specification.

DIMENSIONS

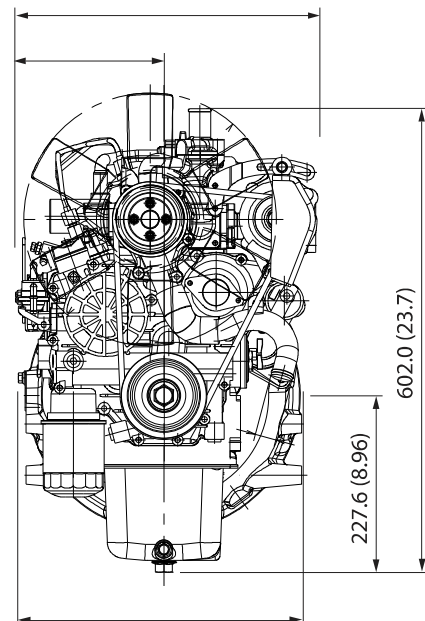
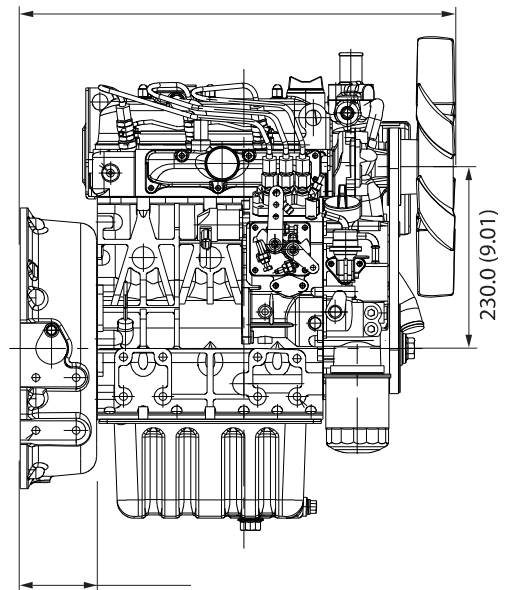

Kubota Corporation

2-47, Shikitsuhigashi 1-chome, Naniwa-ku, Osaka, 556-8601 Japan
 Fax: +81 (0) 6 6648 /35 21
<http://www.engine.kubota.ne.jp>

Kubota (Deutschland) GmbH

Senefelder Str. 3-5
 63110 Rodgau

Phone: +49 (0) 6106 / 873 - 113

Fax: +49 (0) 6106 / 873 - 196

eMail: motoren@kubota.de

homepage: www.kubota-motoren.de