

RIGHT ANGLE GEAR DRIVES

FOR COOLING TOWERS



Amarillo[®]
Gear
Company



TABLE I - SINGLE REDUCTION

Service Horsepower Ratings (Service Factor = 2.0)																					
Model	Input RPM	Ratio																			
		2.0	2.5	3.0	3.25	3.5	3.75	4.0	4.25	4.5	4.75	5.0	5.5	6.0	6.5	7.0	7.5	8.0	8.5	9.0	9.5
65	1750	25	25	20	18	17		15		12		10									
	1450	21	21	17	15	14		12		10		8									
	1160	17	17	13	12	11		10		8		7									
85	1750	50	48	45	43	39	36	33	32	28	27	25	20	18	15	15					
	1450	41	40	37	36	32	30	27	26	23	22	21	17	15	12	12					
	1160	33	32	30	29	26	24	22	21	19	18	17	13	12	10	10					
110	1750					75	74	72	71	69	64	60	46	40	33	30	25	24			
	1450					62	61	60	59	57	53	50	38	33	27	25	21	20			
	1160					50	49	48	47	46	42	40	30	27	22	20	17	16			
135	1750					120	117	110	100	93	88	83	71	65	59	48	43	42	35	30	
	1450					99	97	91	83	77	73	69	59	54	49	40	36	35	29	25	
	1160					80	78	73	66	62	58	55	47	43	39	32	29	28	23	20	
155	1750							133	125	119	114	110	100	90	85	75	65	55	50	45	
	1450							110	104	99	94	91	83	75	70	62	54	46	41	37	
	1160							88	83	79	76	73	66	60	56	50	43	36	33	30	
175	1750									145	140	133	126	112	105	100	80	60	60	60	50
	1450									120	116	110	104	92	87	83	66	50	50	50	41
	1160									96	93	88	84	74	70	66	53	40	40	40	33

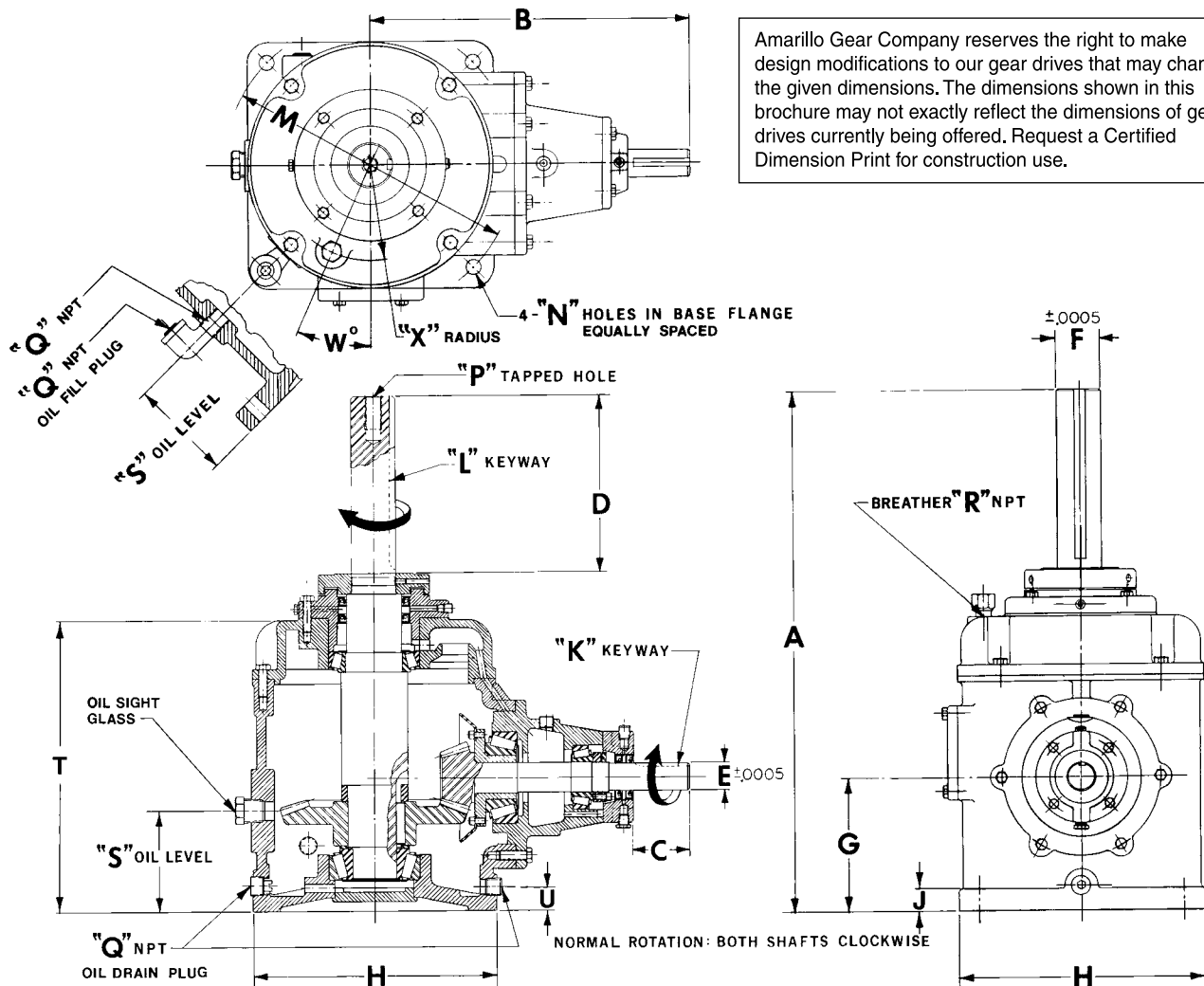

Amarillo Gear Company reserves the right to make design modifications to our gear drives that may change the given dimensions. The dimensions shown in this brochure may not exactly reflect the dimensions of gear drives currently being offered. Request a Certified Dimension Print for construction use.

TABLE II - DIMENSIONS

Model	A	B	C	C with Non-Reverse	D	E	F	G	H	J	K	L	M	N	P	Q	R	S	T	U	W	X	WEIGHT
* 65	17 ³ / ₄	10 ⁷ / ₈	2 ¹ / ₄	2 ¹ / ₄	6	.999	1.749	5	10	5/8	1/4 x 1/8	3/8 x 3/16	9/8	9/16	3/4-10NC	1/2	1/2	5	9 ¹ / ₂	7/8	15	3 ¹ / ₄	90
85	23 ³ / ₄	14 ¹ / ₄	2 ¹¹ / ₁₆	1 ¹⁹ / ₃₂	8	1.249	1.999	6	11	1	5/16 x 5/32	1/2 x 1/4	13	11/16	3/4-10NC	1/2	1/2	4 ⁹ / ₁₆	13 ¹ / ₄	1 ⁹ / ₁₆	0	4 ⁵ / ₁₆	195
110	26 ¹ / ₂	17 ⁵ / ₈	3 ⁵ / ₁₆	2 ¹ / ₁₆	8 ¹ / ₂	1.499	2.374	7	13 ¹ / ₂	1 ¹ / ₈	3/8 x 3/16	5/8 x 5/16	16	11/16	3/4-10NC	3/4	1/2	5 ¹ / ₂	15 ⁵ / ₈	1 ⁷ / ₁₆	0	4 ⁵ / ₈	325
135	29 ⁹ / ₈	21	3 ³ / ₄	2 ⁵ / ₁₆	9	1.874	2.624	8	16	1 ¹ / ₄	3/8 x 3/16	5/8 x 5/16	20	19/16	3/4-10NC	3/4	1/2	6	18 ¹ / ₈	1 ³ / ₈	54	5	500
155	31 ¹¹ / ₁₆	23 ¹ / ₁₆	3 ⁷ / ₈	2 ¹ / ₂	9 ¹ / ₂	1.874	2.999	9 ¹ / ₂	19	1 ¹ / ₄	3/8 x 3/16	3/4 x 3/8	22	19/16	3/4-10NC	3/4	1/2	7	19 ³ / ₄	1 ³ / ₈	54	6 ³ / ₈	675
175	33 ³ / ₈	23 ¹ / ₂	3 ⁹ / ₁₆	2 ¹ / ₈	9 ¹ / ₂	1.874	2.999	9 ¹ / ₂	20 ¹ / ₂	1 ¹ / ₂	3/8 x 3/16	3/4 x 3/8	25	19/16	3/4-10NC	3/4	1/2	7 ¹ / ₂	21 ¹ / ₂	1 ¹ / ₂	54	7	825

* Model 65 has a 10" Diameter Base

Cover Shows: Gear drive, composite drive shaft manufactured by Amarillo Gear Co. Mechanical support and electric motor manufactured by others.

TABLE III - DOUBLE REDUCTION

Service Horsepower Ratings (Service Factor = 2.0)																				
Model	Input RPM	Ratio*																		
		7.5	8	8.5	9	9.5	10	10.5	11	12	12.5	13	14	15	15.5	16	17	18	19	20
1008	1750	100	100	100	100	95	90	86	82	75		75	60	60						33
	1450	83	83	83	83	79	75	71	68	62		62	50	50						27
	1160	66	66	66	66	63	60	57	54	50		50	40	40						22
1110	1750	142	142	141	140	135	130	130	130	125		125	120	100	97	95	90			75
	1450	118	118	117	116	112	108	108	108	104		104	99	83	80	79	75			62
	1160	94	94	93	93	89	86	86	86	83		83	80	66	64	63	60			50
1311	1750		210	208	206	198	190	183	176	165		160	155	150	148	147	137	129	117	110
	1450		174	172	171	164	157	151	146	137		133	128	124	123	122	114	107	97	91
	1160		139	138	137	131	126	121	117	109		106	103	99	98	97	91	86	78	73
1712	1750		330	321	312	300	290	280	271	255	255	241	229	214	207	200	188	178	169	161
	1450		273	266	259	249	240	232	225	211	211	200	190	177	171	166	156	147	140	133
	1160		219	213	207	198	192	186	180	169	169	160	152	142	137	133	125	118	112	107
1712.5	1750						334	321	309	297		279	262	252	244	236	231	225	201	193
	1450						277	266	256	246		231	217	209	202	196	191	186	167	160
	1160						221	213	205	197		185	174	167	162	156	153	149	133	128
1713	1750							392	390	343		323	310	300	294	285	272	262	250	241
	1450							325	323	284		268	257	249	244	236	225	217	207	200
	1160							260	259	227		214	205	199	195	189	180	174	166	160
1814	1750									454		419	389	363	356	345	324	309	291	279
	1450									376		346	322	301	295	286	268	255	241	231
	1160									301		277	258	241	236	229	215	204	192	184
2016	1750											500	480	460	454	440	420	400	380	360
	1450											414	398	381	376	365	348	331	315	298
	1160											331	318	305	301	292	278	265	252	239

TABLE IV - VERTICAL SHAFT DOWN THRUST CAPACITY (Pounds)

Model	Thrust	Model	Thrust
65	1500	1008	3800
85	1750	1110	5400
110	2650	1311	5950
135	2500	1311W	12000
155	4700	1712	8900
175	5150	1712W	13000
		1712.5	9250
		1712.5W	13500
		1713	10900
		1713W	16000
		1814	17000
		2016	17000

Thrust ratings vary greatly depending upon the transmitted power and the vertical shaft speed. The ratings in TABLE IV are the axial loads that can be applied to the fan shaft which will always result in a calculated bearing life greater than 100,000 hours L₁₀. These ratings are based on the worse case from the power rating tables. All models can be supplied with larger thrust bearings or special bearing arrangements. Contact the factory when the fan loading conditions or the bearing life requirements cannot be satisfied with the ratings from the tables.

TABLE VI - EXACT RATIO

MODEL	2.0	2.5	3.0	3.25	3.5	3.75	4.0	4.25	4.5	4.75	5.0	5.5	6.0	6.5	7.0	7.5	8.0	8.5	9.0	9.5
65	2.00	2.47	2.94	3.27	3.54		3.92		4.55		4.90									
85	2.05	2.56	3.00	3.23	3.50	3.75	4.00	4.27	4.55	4.70	5.00	5.56	6.00	6.56	7.00					
110					3.46	3.77	4.00	4.25	4.45	4.73	5.00	5.50	6.00	6.56	7.00	7.50	8.00			
135					3.50	3.73	4.00	4.25	4.50	4.73	5.00	5.50	6.00	6.56	7.00	7.50	8.00	8.57	9.00	
155							4.00	4.21	4.54	4.77	5.08	5.58	6.00	6.56	7.11	7.50	8.00	8.50	9.00	
175									4.54	4.71	5.08	5.58	6.09	6.60	7.10	7.56	8.13	8.50	9.14	9.57

MODEL	7.5	8	8.5	9	9.5	10	10.5	11	12	12.5	13	14	15	15.5	16	17	18	19	20	25
1008	7.53	7.97	8.72	8.96	9.64	9.90	10.43	11.08	11.94		12.93	13.93	14.86						19.81	
1110	7.50	7.96	8.52	8.96	9.35	10.19	10.50	11.05	11.96		12.94	14.06	15.00	15.58	16.07	16.92			20.00	
1311		8.00	8.72	9.04	9.45	9.90	10.46	11.14	12.16		12.93	13.93	14.86	15.79	16.18	17.33	18.04	18.67	19.81	24.76
1712		8.16	8.50	9.04	9.45	9.90	10.60	11.16	12.20	12.50	12.94	14.00	15.00	15.50	16.25	16.86	18.15	18.86	20.31	25.20
1712.5						10.05	10.58	11.18	11.85		12.97	13.98	14.69	15.40	15.98	17.21	17.88	19.25	19.83	24.82
1713							10.53	11.20	12.27		13.13	13.82	15.11	15.48	16.03	17.34	18.27	18.58	20.13	25.15
1814									12.06		13.15	14.21	15.23	15.50	16.07	16.88	18.24	18.82	20.02	25.04
2016											13.04	13.86	15.25	15.50	16.05	16.84	17.94	18.67	20.00	25.00

TABLE V - WEIGHTS & SHIPPING DIMENSIONS

Model	Domestic Shipping Weight (lbs)	Weight with Export Boxing (lbs)	Export Box Dimensions (L x W x H) (in)
65	100	135	22 x 14 x 21
85	215	245	27 x 15 x 27
110	350	395	29 x 19 x 34
135	530	550	36 x 23 x 34
155	705	855	40 x 27 x 41
175	855	940	40 x 27 x 41
1008	875	980	40 x 27 x 41
1110	1375	1485	48 x 28 x 41
1311	1690	1775	48 x 28 x 41
1311W	2025	2155	48 x 35 x 43
1712	2125	2230	50 x 30 x 44
1712W	2585	2725	50 x 36 x 48
1712.5	2400	2540	50 x 32 x 43
1712.5W	2860	3000	51 x 39 x 45
1713	2775	3020	55 x 41 x 45
1713W	3600	3855	55 x 47 x 47
1814	4270	4530	65 x 50 x 51
2016	6690	6970	70 x 46 x 55

DOUBLE REDUCTION

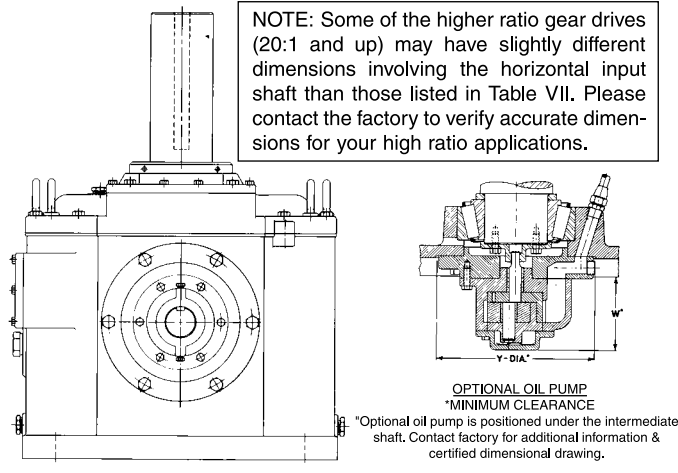
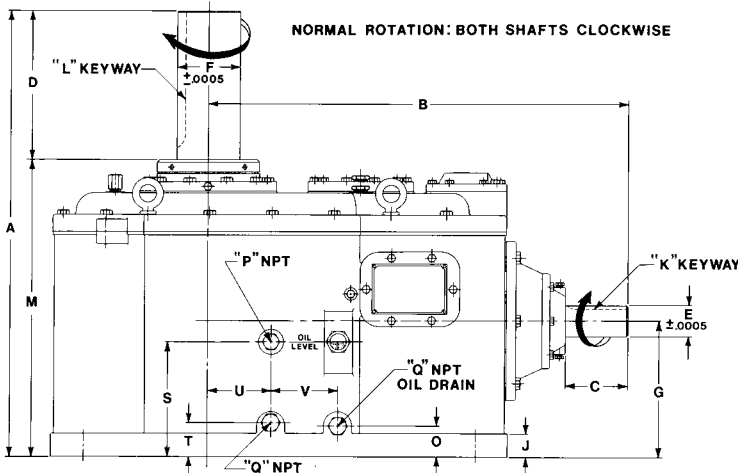
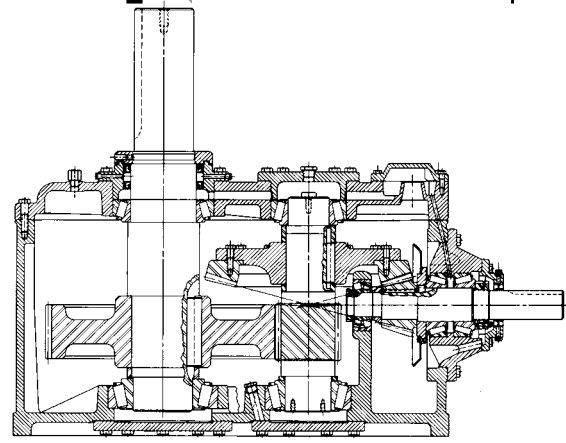
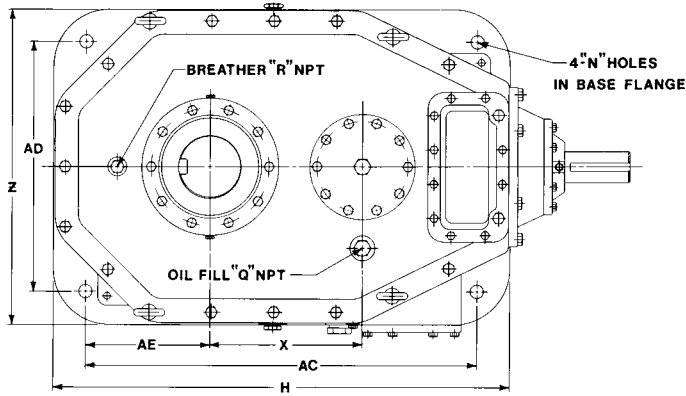

TABLE VII - DIMENSIONS

Model	A	B	C	C with Non-Reverse	D	E	F	G	H	J	K	L	M	N	O
1008	28 1/2	26	3 3/4	2 1/4	10	1.874	3.499	8 1/2	25 1/4	1 7/8	3/8 x 3/16	7/8 x 7/16	18 1/2	1 1/16	2 1/8
1110	32 5/8	29 3/4	3 3/4	2 1/4	12	1.874	3.999	9 1/2	30 1/4	1 7/8	3/8 x 3/16	1 x 1/2	20 5/8	1 1/16	2 1/8
1311	34 3/8	30 7/16	4 15/16	3 1/4	12	2.436	4.499	10 1/4	33 1/4	1 7/8	5/8 x 5/16	1 x 1/2	22 3/8	1 5/16	1 1/2
1311W*	35 7/8	30 7/16	4 15/16	3 1/4	12	2.436	4.499	11 3/4	33 1/2	1 1/2	5/8 x 5/16	1 x 1/2	23 7/8	1 5/16	3
1712	35 7/8	33 3/4	4 15/16	3 1/4	12	2.436	4.999	11	36 3/4	1 7/8	5/8 x 5/16	1 1/4 x 5/8	23 7/8	1 5/16	1 11/16
1712W*	37 3/8	33 3/4	4 15/16	3 1/4	12	2.436	4.999	12 1/2	37	1 1/2	5/8 x 5/16	1 1/4 x 5/8	25 3/8	1 5/16	3 3/16
1712.5	36 7/8	35 3/4	5 13/16	3 1/2	12	2.936	4.999	12	36 3/4	1 7/8	3/4 x 3/8	1 1/4 x 5/8	24 7/8	1 5/16	1 11/16
1712.5W	38 3/8	35 3/4	5 13/16	3 1/2	12	2.936	4.999	13 1/2	37	1 1/2	3/4 x 3/8	1 1/4 x 5/8	26 3/8	1 5/16	3 3/16
1713	38 1/8	37 1/4	5 13/16	3 1/2	12	2.936	5.499	12	40 7/8	1 1/2	3/4 x 3/8	1 1/4 x 5/8	26 1/8	1 5/16	1 3/4
1713W*	39 5/8	37 1/4	5 13/16	3 1/2	12	2.936	5.499	13 1/2	41	1 1/2	3/4 x 3/8	1 1/4 x 5/8	27 5/8	1 5/16	3 1/4
1814	44 3/4	39 1/4	5 7/8	5 7/8	15	3.124	6.498	14 1/2	44 1/4	2 1/2	3/4 x 3/8	1 1/2 x 3/4	29 3/4	1 9/16	2
2016	48 5/8	43 3/4	6	6	15	3.499	7.498	16	52 3/4	3	7/8 x 7/16	1 3/4 x 7/8	33 5/8	1 13/16	2 5/8

Model	P	Q	R	S	T	U	V	W	X	Y	Z	AC	AD	AE	WEIGHT
1008	3/4	1	1/2	7	2 3/4	1 1/2	3 1/2	2 7/8	8 1/4	10	18 1/2	21 1/4	14 1/2	7 1/4	830
1110	3/4	1	1/2	7	2 3/4	1 3/4	4	2 7/8	10	10	22	26	18	8 7/8	1245
1311	3/4	1	1/2	7 7/8	2 3/4	2 3/4	4	6 13/16	11	10	23 1/2	29 1/4	19 1/2	10 3/8	1575
1311W*	3/4	1	1/2	9 3/8	4 1/4	2 3/4	4	5 5/16	11	10	30	29 1/4	27	10 3/8	1950
1712	3/4	1	1/2	9 1/4	2 3/4	5 1/8	5 1/2	6 3/8	12 1/4	10	25 1/4	31 1/2	20	10	2000
1712W*	3/4	1	1/2	10 3/4	4 1/4	5 1/8	5 1/2	4 7/8	12 1/4	10	32	31 1/2	29	10	2460
1712.5	3/4	1	1/2	10 1/4	2 3/4	5 1/8	5 1/2	6 3/8	12 1/4	10	25 1/4	31 1/2	20	10	2280
1712.5W	3/4	1	1/2	11 3/4	4 1/4	5 1/8	5 1/2	4 7/8	12 1/4	10	32	31 1/2	29	10	2740
1713	3/4	1	1/2	9 1/4	3 1/4	3 5/8	5 7/16	6 3/8	13 3/4	10 1/2	29 1/4	34 7/8	23 1/4	11 5/8	2600
1713W*	3/4	1	1/2	10 3/4	4 3/4	3 5/8	5 7/16	4 7/8	13 3/4	10 1/2	36	34 7/8	33	11 5/8	3180
1814	3/4	1	1/2	11 1/4	3 3/4	5 1/16	4 7/8	5 5/16	14 1/2	10	31 7/8	37 1/4	24 7/8	12 7/16	3850
2016	3/4	1	1/2	12 1/4	5	5 1/2	8 7/8	5 5/16	16 1/2	10	38 1/4	44 3/4	30 1/4	15 1/8	6390

* The W series incorporates design provisions to counter the very high thrust and undefined loads that are often encountered with applications involving very large fans. Please contact the factory to discuss your applications that might require the W Series gear drives. Dimensions include supplied base plate.



Each Amarillo Gear Company fan drive is the result of careful design and manufacturing technique. As with any precision machine component, proper selection, installation, maintenance and operating procedures are imperative for long life and trouble-free service. The following instructions are offered for selection of gear drives for usual applications. Our engineers will be pleased to assist when unusual conditions require special procedures.

Ratio

All ratios are reducing and defined as the ratio of input speed to output speed. Single reduction ratios shown in Table I are exact within $\pm 2\%$. Double reduction ratios shown in Table III are exact within $\pm 3\%$. Intermediate and special ratios are available within the limits shown in the tables.

Ratings

AGMA and CTI recommend a minimum service factor of 2.0 for gear drives in cooling tower fan service when driven by electric motors or steam turbines. All ratings in Table I and Table III are service ratings and include a 2.0 service factor. Ratings are listed for both 60 and 50 cycle electric motor speeds. Ratings at intermediate speeds may be interpolated from the tables. Contact the factory for recommendations when the driver speed exceeds 1800 rpm.

Thermal Rating

The thermal ratings of Amarillo Gear cooling tower drives are equal to or exceed the service ratings listed in Tables I & III when the discharge air temperature is 120°F or less. Contact the factory for thermal rating when the air temperature exceeds 120°F.

Selection

The required ratio is established by dividing the input or driver speed by the output or fan speed. Select the ratio from the table that is the closest to the required ratio. Select a gear drive from the table that has a service rating listed under the required ratio column that is equal to or greater than the power rating of the driver at the input speed. When gear drives are to be selected using a service factor other than 2.0, multiply the "service rating" from the tables by 2.0 to get the "mechanical rating." The "mechanical rating" is then divided by the appropriate service factor to obtain the new "service rating" at the required service factor.

Limited Warranty

The Amarillo Gear Company Right Angle Gear Drive is guaranteed against defects in workmanship and material for a period of one year after installation when operated under normal service at rated capacity. Within the above stated period, the manufacturer will replace the defective parts returned transportation prepaid. The buyer shall not be entitled to incidental or consequential damages, losses or expenses. The guarantee will not apply to repairs made outside the factory without the consent of the manufacturer or to drives that have been subject to abuse, accident, neglect, or improper installation. No warranty is made in regard to bearings, trade accessories, machinery, or other articles of merchandise not manufactured by us. **This warranty is expressly made in lieu of any warranties otherwise expressed or implied by law.**

Direction of Rotation

Normal rotation is both shafts clockwise as shown in the illustrations. Occasional use with both shafts rotating counterclockwise is permissible. Special bearing arrangements are used when the primary direction of rotation is counterclockwise and the gear drives should be ordered accordingly.

"W" Series

The "W" Series of gear drives were developed primarily for applications involving larger diameter fans. These applications may require special design features to be incorporated in the gear drives to accommodate the higher thrust and undefined dynamic loads which are normally associated with larger diameter fans. Contact Amarillo Gear to discuss any applications involving 36 foot or larger diameter fans.

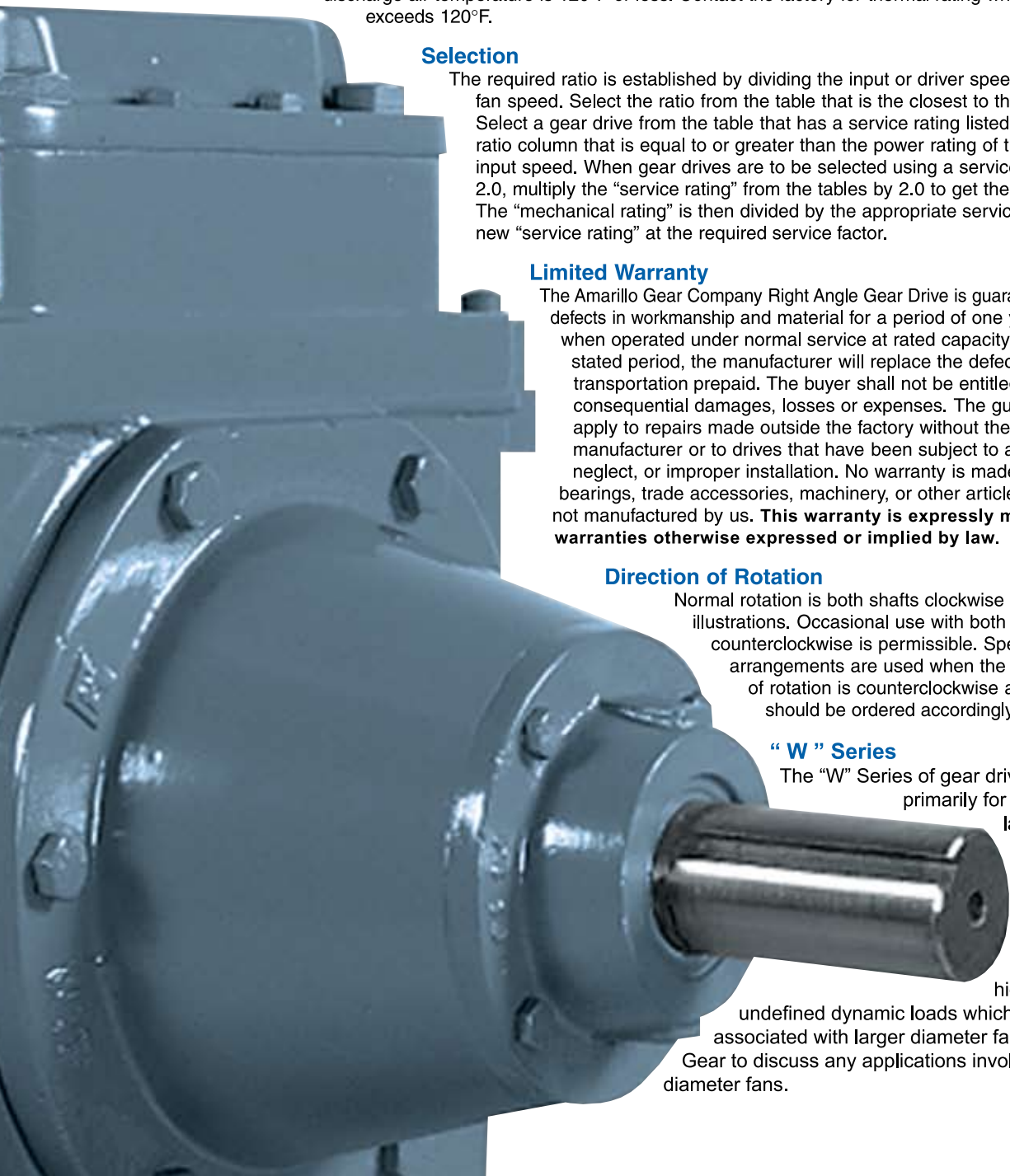

Right Angle Gear Drives For Cooling Towers

The drives Amarillo Gear Company produces for cooling tower and air fin heat exchanger service reflect a long history of quality workmanship and reliability. Amarillo Gear has been designing and manufacturing right angle drives since 1934, and the commitment to excellence continues today. One example of this commitment is the availability of complete noise and vibration testing, with all data taken under full horsepower loading up to 500 hp.

Amarillo Gear drives also are made available for, and are commonly used with, many other applications. The basic design and inherent ruggedness of Amarillo Gear drives is adaptable to many types of vertical machines such as agitators, mixers, dryers and separators.

Features

Design features and ratings are in accordance with, or exceed, the minimum requirements of AGMA (American Gear Manufacturers Association) and CTI (Cooling Technology Institute) standards.

Housing and Castings

Castings are rigidly designed and constructed to absorb internal and external loads with minimum deflection. Gear case and cover are manufactured to assure permanent alignment of bearings and gears under load. The sloped floor of the gear case adds rigidity and permits complete oil drainage. All casting materials are gray cast iron for effective damping of noise and vibration. All mating castings are sealed using "formed-in-place" gasket material that eliminates "weeping" associated with fiber-type gaskets. Gear cases are pre-drilled with pilot holes to assist in installation of dowel pins.

Spiral Bevel Gears

Designed and manufactured by Amarillo Gear Company for fan drive service. All spiral bevel gears are precision machined from high grade alloy steel, case hardened and lapped in pairs.

Helical Gears

Helical gears are designed specifically for fan drive service and are precision machined from high grade alloy steel, case hardened and precision ground to provide low-noise, low vibration operation.

Bearings

All bearings are roller type, provided by major manufacturers. The fan shaft thrust bearing is designed to carry all loads imposed by the fan while maintaining 100,000 hours L_{10} life. All bearings are sized to meet or exceed the minimum life requirements of AGMA and CTI.

Quiet Operation

Quiet operation of the Amarillo Fan Drives is achieved through careful design and controlled manufacturing methods of components. Our engineers understand all of the many parameters that affect gear noise and have applied the latest research to the design and manufacture of all components. Parameters that reduce gear noise are controlled during design, manufacturing, and assembly to ensure quiet operation. Rigid shafts and permanently aligned housings guarantee alignment of gears under load. Test results collected in our state-of-the-art test facility prove that our sound levels are the lowest available in the industry.

Shafting

Amply sized to provide a rugged spindle for the fan. Surfaces for gears, bearings, input coupling and fan hub are precision ground.

Shaft Seals

Both the input and output shaft openings have dual spring-loaded, single-lipped type seals to keep outside contamination from entering the gearbox. Plus, the output shaft has a labyrinth-type plate directly mounted to the shaft to triple protect the gearbox from contamination that might try to enter due to the natural effect of gravitation.

Lubrication

Oversize slinger on the input shaft provides adequate lubrication in either direction or at half speed operation. Continuous circulation of oil to all bearings is assured by location of channels and baffles. Double reduction units can also be supplied with a positive displacement bi-directional oil pump and oil distribution system to all bearings. This pump is driven from the intermediate shaft and provides a redundant lubrication system for extreme reliability. A permanently mounted oil sight level gauge is provided on all units to provide direct visual determination of oil level.

Low Speed Operation

For operation when motor speeds are less than 450 rpm, single reduction fan drives require Amarillo Gear's exclusive "Low Speed" option, and double reduction fan drives require a mechanical oil pump for proper lubrication. The addition of these options allows operation with no minimum input speed restrictions.

Service Openings

Large inspection plate facilitates periodic inspections. Ports for oil fill, oil drain and venting are tapped and located for installation of remote service piping when desired.

Optional Features

Special output shaft extensions, backstops (anti-windmilling), oil level switches, oil heaters & thermostats, oil temperature gauges, spot-face/drill & tap for vibration transducers, "low speed" option, and other accessory items are available on special order.

Catalog CT08/08



Amarillo® Gear Company