

Features

- 2-way normally open operation
- For control of commercial and industrial gas burners
- Ideal for high pressure applications
- Brass body construction
- Mountable in any position

Fluid

Fuel Gas

Construction

Valve Parts in Contact with Fluids	
Body	Brass
Seals and Disc	NBR
Core Tube	305 Stainless Steel
Core and Plugnut	430F Stainless Steel
Springs	302 Stainless Steel
Shading Coil	Copper

Electrical

Standard Coil Class of Insulation	Watt Rating and Power Consumption			Ambient Temp. °F	Spare Coil Family	
	AC				General Purpose	Explosionproof
	Watts	VA Holding	VA Inrush		AC	AC
F	10.1	25	70	32 to 125	238610	238614
H	10.1	25	70	32 to 140	238810	238914

Standard Voltages: 24, 120, 240 volts AC, 60 Hz (or 110, 220 volts AC, 50 Hz).
Optional High Ambient Temp: 140°F Class H coil with prefix HT.

Solenoid Enclosures

Standard: Watertight, Types 1, 2, 3, 3S, 4, and 4X with 1/2" conduit hub.

Optional: RedHat II - Explosionproof and Watertight. To order, add Prefix "EF" to catalog numbers. (e.g. EF8210G034)

Valve Response Time

Opening Time: Less than 1 second

Closing Time: Less than 1 second

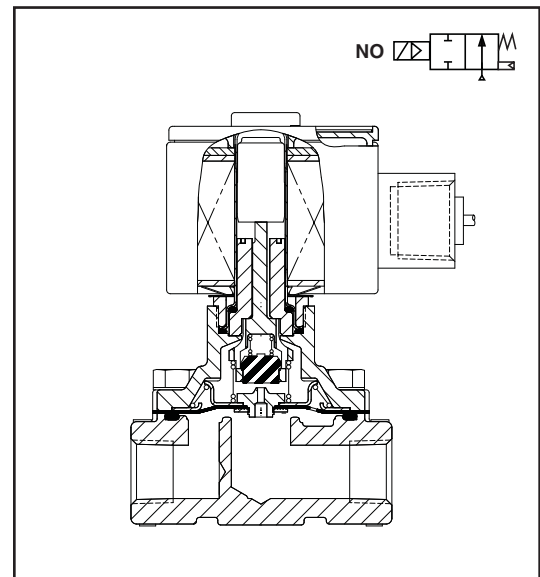

Approvals

UL listed to standard 429 "Electrically Operated Valves," Guide YIOZ, File MP618, General Purpose Valves.

CSA Certified to:

Standard C22.2 No. 139 "Electrically Operated Valves," File 010381.

Specifications (English units)

Pipe Size (in)	Orifice Size (in)	Cv Flow Factor	Gas Capacity ①	Operating Pressure Differential (psi)		Max. Fluid Temp. °F	Catalog Number	Const. Ref.	Agency			Wattage	Approx. Shipping Weight (lbs)
				Btu/hr.	Min.				Max.	UL	FM		
COMBUSTION (Fuel Gas) - NORMALLY OPEN													
3/8	5/8	2.8	150,000	0	125	180	8210G033	1	●	-	●	10.1	3.4
1/2	5/8	3.5	188,000	0	125	180	8210G034	1	●	-	●	10.1	3.4
3/4	3/4	5.5	295,000	0	125	180	8210G035	2	●	-	●	10.1	3.6

● = General Purpose Valve. ① 1" W.C. Drop @ 2" W.C. Inlet Pressure, 1,000 Btu/cu.ft. or more, 0.64 Specific Gravity Gas.

Specifications (Metric units)

Pipe Size (in)	Orifice Size (mm)	Kv Flow (m³/hr)	Gas Capacity ①	Operating Pressure Differential (bar)		Max. Fluid Temp. °C	Catalog Number	Const. Ref.	Agency			Wattage	Approx. Shipping Weight (kgs)
				Btu/hr.	Min.				Max.	UL	FM		
COMBUSTION (Fuel Gas) - NORMALLY OPEN													
3/8	16	2.4	150,000	0	8.6	82	8210G033	1	●	-	●	10.1	1.5
1/2	16	3.0	188,000	0	8.6	82	8210G034	1	●	-	●	10.1	1.5
3/4	19	4.7	295,000	0	8.6	82	8210G035	2	●	-	●	10.1	1.6

● = General Purpose Valve. ① 1" W.C. Drop @ 2" W.C. Inlet Pressure, 1,000 Btu/cu.ft. or more, 0.64 Specific Gravity Gas.

Capabilities Chart

Solenoid Options				Base Catalog Number	Resilient Materials	Standard Rebuild Kit
NEMA Type 3-9	High Temp.	Junction Box	Wiring Box Screw Terminal	Brass	NBR	AC
EF	HT	JB	JKF	8210G033	●	302334
EF	HT	JB	JKF	8210G034	●	302334
EF	HT	JB	JKF	8210G035	●	302335

● = Standard. Other options may be available. All option combinations may not be available.

Dimensions inches (mm)

Const. Ref.		A	B	H	J	K	L	N	P	T	W
1	in	1.66	3.03	4.35	2.04	2.65	2.75	3.42	3.79	1.95	2.28
	mm	42	77	110	52	67	70	87	96	50	58
2	in	1.66	3.03	4.64	2.04	2.81	2.81	3.45	3.94	1.95	2.28
	mm	42	77	118	52	71	71	88	100	50	58

Const. Ref. 1, 2

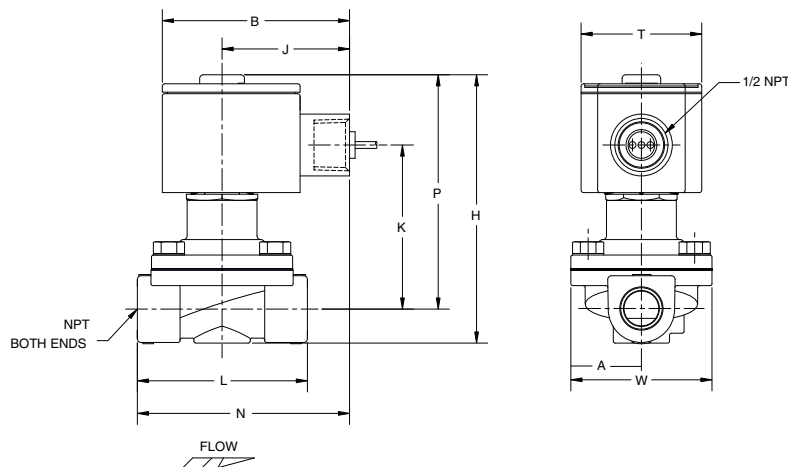

Mountable in any position.

COMBUSTION