



Circuit Setter Plus[®] Calibrated Balance Valves

Accurate Flow Control

- Pre-balance design capability
- Proportional balance capability
- Positive shut off
- Memory stop indicator
- Integral valved readout ports



Bell & Gossett[®]



ITT Industries
Engineered for life

CIRCUIT SETTER CALIBRATED BALANCE VALVE

The CIRCUIT SETTER calibrated balance valve is designed specifically for pre-set proportional system balance. This system balance method, developed by B&G, assures optimum system flow balance at minimum operating horsepower. Balance valves can be simply pre-set using the B&G Circuit Setter Calculator or

CIRCUIT SETTER PLUS NPT AND SWEAT MODELS

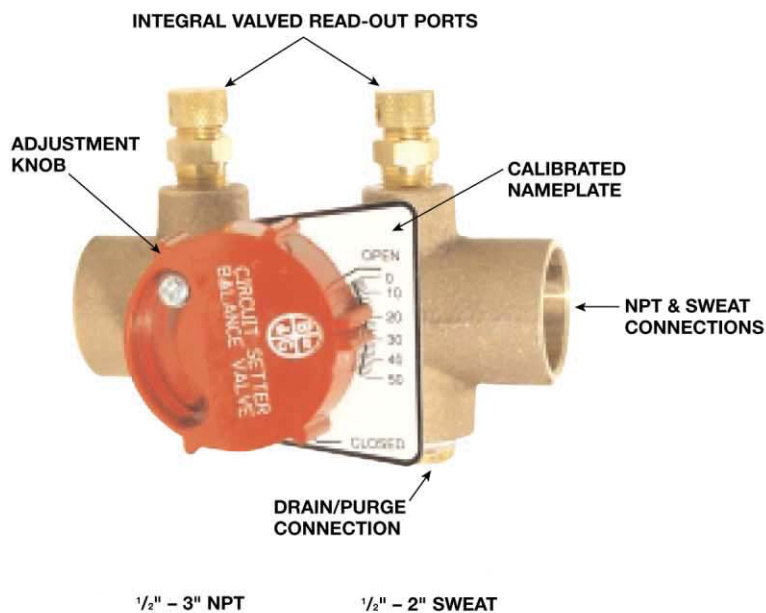

- **PROPORTIONAL BALANCE**
Permits rapid accurate system balance
- **POSITIVE SHUT-OFF**
For isolation and service
- **MEMORY STOP**
Allows complete shut-off and return to set position without readjustment
- **READOUT VALVES**
To facilitate differential pressure readings
- **DRAIN CONNECTION**
Circuit Setter Plus models only:
Permits draining of terminal units without draining circuit piping

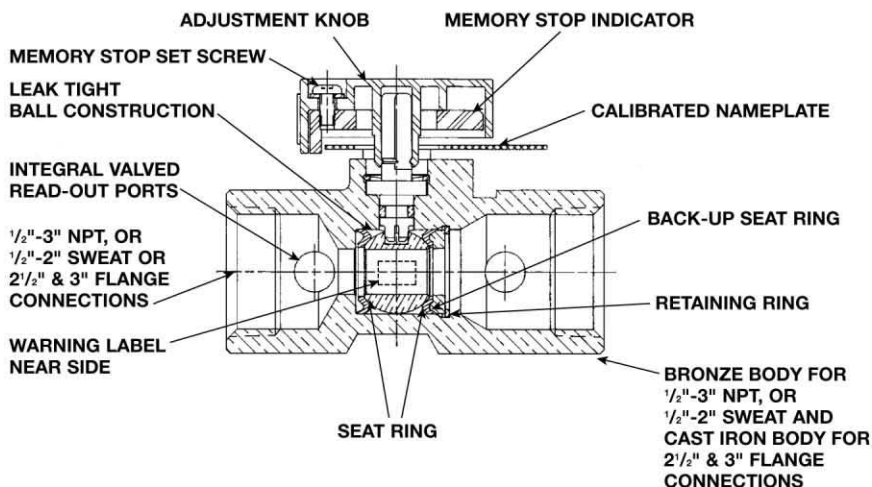

Quality manufacturing and materials provide leak-tight construction and repeatable performance in every valve. The precision machined brass ball is backed up with 20% glass and carbon filled TFE seat rings. Valve seats do not distort with extended use. Permanent valve accuracy is assured.

FLANGED AND GROOVED MODELS

Curve Booklet A560 and the system piping plan. With this procedure, system balance and start-up time is reduced dramatically. Pump impeller trim after system balance will reduce system horsepower and operating costs to minimum levels.

FLANGED AND GROOVED MODELS

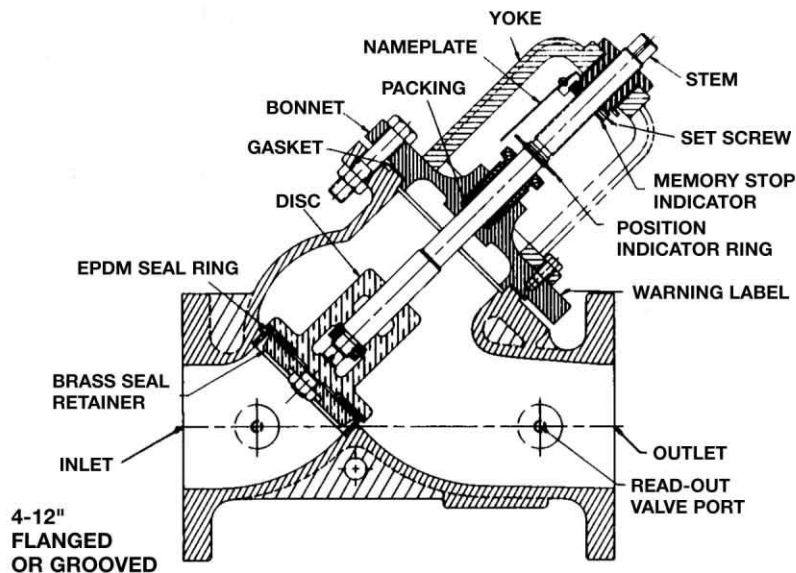
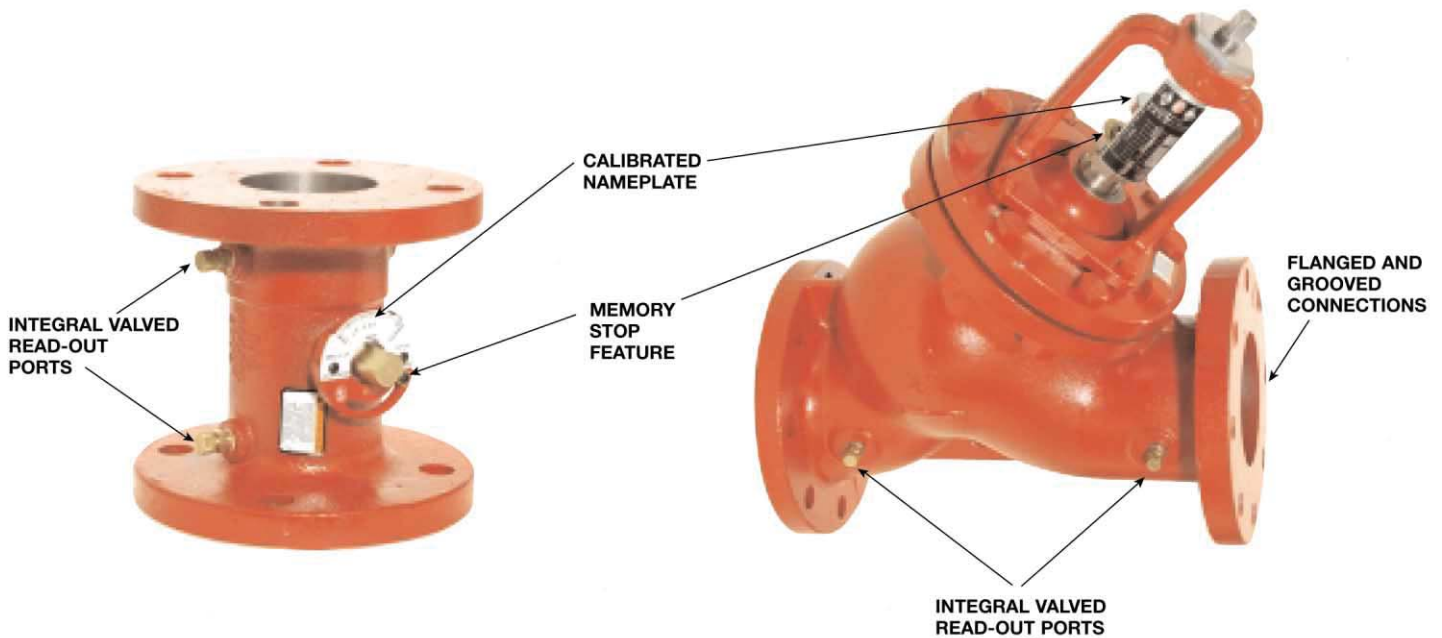

The globe style valve incorporates a contoured brass plug which enhances the precision balancing capabilities of the valve. The durable EPDM seal ring allows for drop tight shut off even through extended use. A positive metal to metal lock is ensured by the memory stop indicator.

A balance valve, a flow meter, a drip tight service valve

CIRCUIT SETTER ASSURES OPTIMUM SYSTEM FLOW BALANCE WITH MINIMUM HORSEPOWER

The B&G CIRCUIT SETTER PLUS calibrated balance valve has been designed, manufactured and tested to provide the cost saving advantages of pre-set proportional balance. Each valve is a three function precision instrument providing flow balance, flow metering and shut-off.

VELOCITY HEAD RECOVERY

Changes in fluid velocity through the valve orifice are as illustrated. Actual pressure drop imposed against the pump (ΔP from C to D) is on the order .7 to .9 of the value as read across the read-out ports A-B. These differences are significant enough to require two different sets of ΔP data to be shown on the Circuit Setter Balance Valve Calculator.

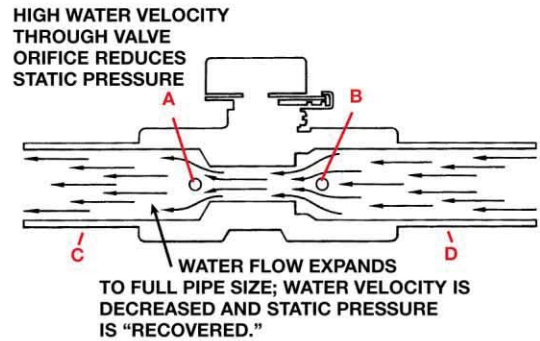

CIRCUIT SETTER BALANCE VALVE CALCULATOR

The Circuit Setter Calculator is the result of rigorous laboratory tests. Side 1 plots actual system imposed head loss versus flow for various valve settings. This scale is used for pre-set balance determination. Side 2 is used when taking gauge readings across the Circuit Setter balance valve – using the valve as a flow meter.

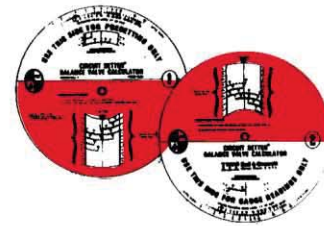

VARIABLE ORIFICE FLOW METER

Circuit Setter balance valves can be used as a variable orifice flow meter. A ΔP meter is applied directly across the valved read-out ports. Determine flow rate by using Side 2 of the Circuit Setter Calculator.

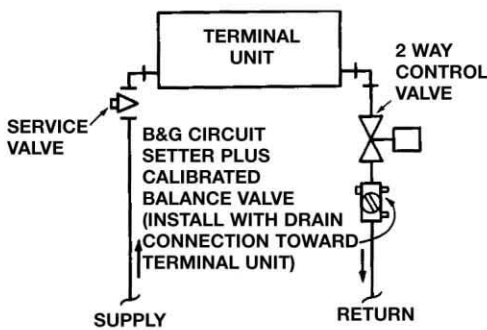
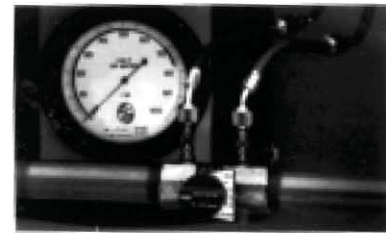

FIGURE 1
PIPING ARRANGEMENT
WITH 2 WAY CONTROL VALVE

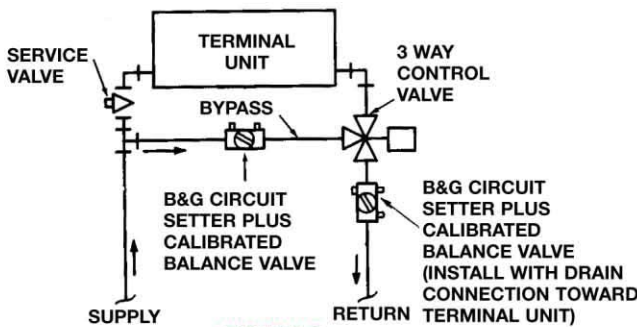

FIGURE 2
PIPING ARRANGEMENT
WITH 3 WAY CONTROL VALVE

For hydronic applications

When terminal equipment and control valves are piped as illustrated (Figures 1 and 2) the combined use of a service valve and the Circuit Setter Plus calibrated balance valve permits complete isolation of the terminal unit and control valve. Drain connection on Circuit Setter balance valve should be toward terminal unit.

A typical piping arrangement for installing Circuit Setters to balance branches and terminal units is shown in Figure 3.

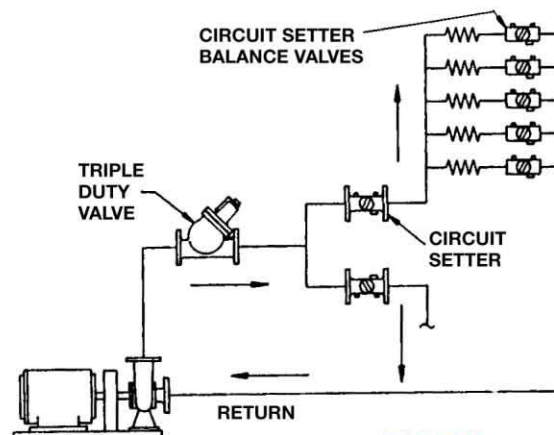
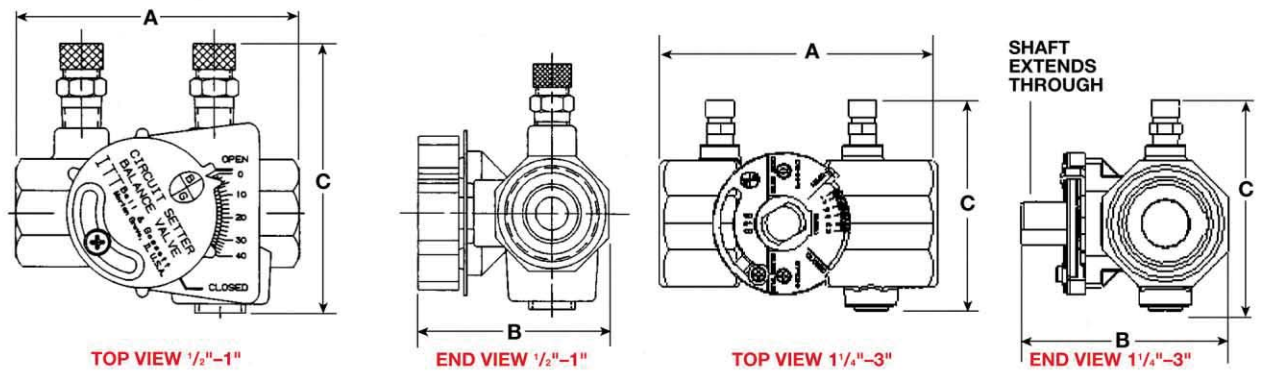

FIGURE 3



NOTE:

Bell & Gossett Circuit Setter Balance Valves are not recommended for use with read-out connections pointing down.

All models are designed for positive shut-off and service.

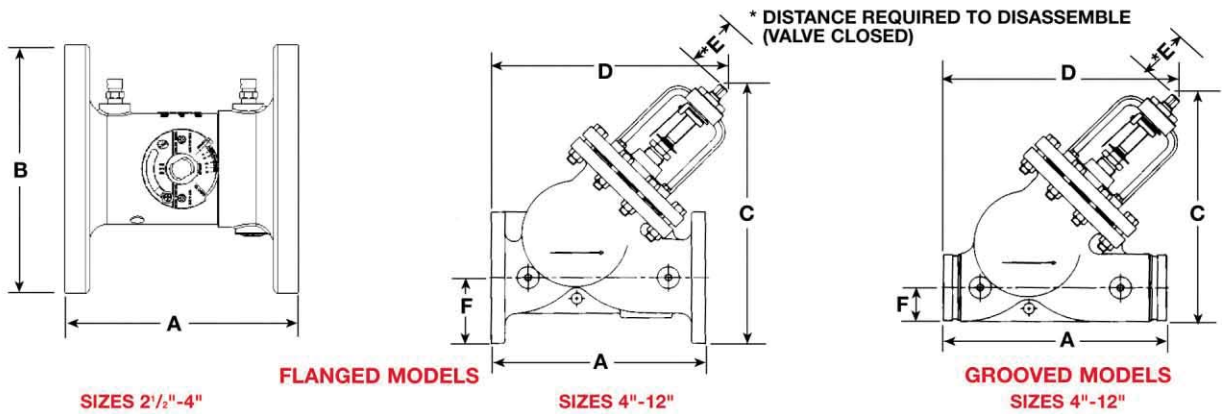

DIMENSIONS AND WEIGHTS

| MODEL NO. | PART NO. | SIZE | CONNS. | DIMENSIONS IN INCHES (MM) | | | | | | | | | | | | MAX. WIDTH OF VALVE | WEIGHT IN LBS.(KG) | | |
|------------|----------|-------|---------------|---------------------------|---------------|--------------|--------------|--------------|--------------|---------------|---------------|---------------|---------------|---------------|--------------|---------------------|--------------------|------------|-------------|
| | | | | A | | B | | C | | | | D | | E | F | | | | |
| | | | | NORMAL | INSUL | NORMAL | INSUL | NORMAL | INSUL | OPEN | CLOSED | OPEN | CLOSED | | | | | | |
| CB-1/2S | 117412 | 1/2 | Sweat | 2 1/4(74.6) | — | 2 1/4(54.0) | — | 2 1/4(65.1) | — | — | — | — | — | — | — | — | — | 1(5) | |
| CB-3/4S | 117413 | 3/4 | | 3 1/4(88.9) | 4 1/4(123.8) | 2 1/4(57.2) | 3 1/4(98.4) | 2 1/4(69.9) | 6 1/4(165.1) | — | — | — | — | — | — | — | — | 1 1/4(6) | |
| CB-1S | 117401 | 1 | | 4 1/4(108.7) | — | 2 1/4(60.3) | — | 3 1/2(84.9) | — | — | — | — | — | — | — | — | — | 2(9) | |
| CB-1 1/4S | 117402 | 1 1/4 | | 4 3/4(124.6) | — | 3 1/4(98.1) | — | 3 1/4(85.7) | — | — | — | — | — | — | — | — | — | 3(1.4) | |
| CB-1 1/2S | 117403 | 1 1/2 | | 5 1/2(132.6) | — | 3 1/2(83.3) | — | 4(101.6) | — | — | — | — | — | — | — | — | — | 3 3/4(1.6) | |
| CB-2S | 117404 | 2 | | 6 1/4(160.3) | — | 3 3/4(99.2) | — | 4 1/4(113.5) | — | — | — | — | — | — | — | — | — | 5 1/4(2.5) | |
| CB-1/2 | 117414 | 1/2 | NPT | 2 1/4(74.6) | — | 2 1/4(55.6) | — | 2 1/4(69.9) | — | — | — | — | — | — | — | — | — | 1 1/4(6) | |
| CB-3/4 | 117415 | 3/4 | | 3 1/4(77.8) | 4 1/4(123.8) | 2 1/4(60.3) | 3 1/4(98.4) | 2 3/8(74.6) | 6 1/4(165.1) | — | — | — | — | — | — | — | — | 1 1/4(7) | |
| CB-1 | 117416 | 1 | | 3 3/4(96.8) | — | 2 1/4(68.3) | — | 3 3/4(81.0) | — | — | — | — | — | — | — | — | — | 2(9) | |
| CB-1 1/4 | 117103 | 1 1/4 | | 4 1/4(111.1) | — | 3 3/4(83.3) | — | 3 3/4(88.9) | — | — | — | — | — | — | — | — | — | 3 1/4(1.5) | |
| CB-1 1/2 | 117104 | 1 1/2 | | 4 1/4(112.7) | 5 1/4(142.9) | 3 3/4(88.1) | 5(127.0) | 3 3/4(96.8) | 7 1/4(187.3) | — | — | — | — | — | — | — | — | 3 3/4(1.7) | |
| CB-2 | 117105 | 2 | | 5 1/4(130.2) | 6 1/4(158.8) | 4 1/4(102.4) | 5 1/4(141.3) | 4 1/4(108.0) | 7 1/4(196.9) | — | — | — | — | — | — | — | — | 5 1/4(2.5) | |
| CB-2 1/2 | 117106 | 2 1/2 | | 6(152.4) | 7 1/4(193.7) | 4 1/2(115.1) | 6 1/4(171.5) | 4 1/4(119.1) | 8 1/4(219.0) | — | — | — | — | — | — | — | — | 8 1/4(4.0) | |
| CB-2 1/2 F | 117116 | 3 | | Flgd. | 6 3/4(166.7) | — | 7(127.8) | — | — | — | — | — | — | — | — | — | — | 23(10.5) | |
| CB-3 | 117107 | | | NPT | 6 1/4(165.1) | 7 1/4(193.7) | 5 1/2(132.6) | 6 1/4(171.5) | 5 1/4(134.9) | 8 1/4(219.0) | — | — | — | — | — | — | — | — | 12 1/4(5.8) |
| CB-3F | 117117 | 4 | | Flgd. | 6 3/4(173.0) | — | 7 1/4(190.5) | — | — | — | — | — | — | — | — | — | — | — | 29(13.2) |
| CB-4 | 117035 | | | 8(203.2) | — | 9(228.6) | — | — | — | — | — | — | — | — | — | — | — | — | 41(18.5) |
| CB-4F | 117112 | 5 | | Grvd. | 14 1/4(368.3) | — | — | — | — | — | 18 1/4(479.4) | 17 3/4(452.4) | 17 1/4(435.0) | 16(406.4) | 7 1/4(193.7) | 4 1/4(114.3) | 9(228.6) | 100(45.5) | |
| CB-4G | 117118 | | 15 1/4(384.2) | — | — | — | — | — | — | 16 1/4(422.3) | 15 3/4(395.3) | 17 1/4(435.0) | 16(406.4) | — | 2 1/4(57.2) | — | — | 76(34.5) | |
| CB-5F | 117113 | 6 | Flgd. | 16(406.4) | — | — | — | — | — | 20 1/4(519.1) | 19 1/4(487.4) | 18 1/4(466.7) | 17 1/4(435.0) | 5(127.0) | 5(127.0) | 10(254.0) | 120(54.6) | | |
| CB-5G | 117119 | | Grvd. | 17 1/4(435.0) | — | — | — | — | — | 18 3/4(462.8) | 16 3/4(431.0) | 18 1/4(494.4) | 17 1/4(447.7) | 8 1/4(212.7) | 2 3/4(70.6) | — | — | 92(41.8) | |
| CB-6F | 117114 | 8 | Flgd. | 18(457.2) | — | — | — | — | — | 22 1/4(574.7) | 21 1/4(539.0) | 20 1/4(517.5) | 19(482.6) | 9 1/4(247.7) | 5 1/4(139.7) | 11(279.4) | 197(89.6) | | |
| CB-6G | 117120 | | Grvd. | 19(482.6) | — | — | — | — | — | 20 1/4(519.1) | 19 1/4(483.4) | 20 1/4(530.2) | 19 1/4(495.3) | — | 3 3/4(84.1) | — | — | 171(77.7) | |
| CB-8F | 117115 | 10 | Flgd. | 21 1/4(546.1) | — | — | — | — | — | 26 3/4(670.7) | 24 3/4(630.2) | 23 1/4(600.1) | 22 1/4(562.0) | 12 1/4(314.3) | 6 1/4(171.5) | 14 1/4(362.0) | 327(148.6) | | |
| CB-8G | 117121 | | Grvd. | 22 1/4(571.5) | — | — | — | — | — | 23 3/4(608.8) | 22 1/4(568.3) | 23 1/4(600.1) | 22(558.8) | — | 4 1/4(109.5) | — | — | 281(127.7) | |
| CB-10F | 117420 | 12 | Flgd. | 25 1/4(647.7) | — | — | — | — | — | 31 1/4(806.5) | 29 1/4(749.3) | 28 1/4(723.9) | 26 1/4(666.8) | 14 1/4(368.3) | 8(203.2) | 17(431.8) | 455(206.8) | | |
| CB-10G | 117422 | | Grvd. | 26 1/4(673.1) | — | — | — | — | — | 29 1/4(739.8) | 26 1/4(682.6) | 28 1/4(723.9) | 26 1/4(679.5) | — | 5 1/4(136.5) | — | — | 302(137.3) | |
| CB-12F | 117421 | 12 | Flgd. | 30(762) | — | — | — | — | — | 35 1/4(911.2) | 33 1/4(850.9) | 31 1/4(796.9) | 29(736.6) | — | 9 1/4(241.3) | — | — | 695(315.9) | |
| CB-12G | 117423 | | Grvd. | 31(784.4) | — | — | — | — | — | 32 1/4(831.9) | 30 1/4(771.5) | 31 1/4(809.6) | 29 1/4(749.3) | 17 1/4(438.2) | 6 1/4(161.9) | — | — | 470(213.6) | |

* Do not use for construction. Dimensions are approximate and subject to change. Contact factory for certified dimensions.

Typical Specifications

Furnish and install as shown on plans and with manufacturer's recommendations Model CB calibrated balance valves.

PRE-SET BALANCE FEATURE

Valves to be designed to allow installing contractor to pre-set balance points for proportional system balance prior to system start-up in accordance with pre-set balance schedule.

SELECT PARAGRAPHS A or B

A. Valves 1/2" to 2" Pipe Size, NPT or Sweat Valves 2 1/2" and 3" Pipe Size, NPT

VALVE DESIGN AND CONSTRUCTION

All valves to be of bronze body/brass ball construction with glass and carbon filled TFE seat rings. Valves to have differential pressure read-out ports across valve seat area. Read-out ports to be fitted with internal EPT insert and check valve. Valve bodies to have 1/4" NPT tapped drain/purge port. Valves to have memory stop feature to allow valve to be closed for service and then reopened to set point without disturbing balance position. All valves to have calibrated nameplate to assure specific valve setting. Valves to be leak-tight at full rated working pressure.

DESIGN PRESSURE/TEMPERATURE

- 1/2"-3" NPT connections:
300 psig (2069 kPa) at 250°F (121°C)
- 1/2"-2" Sweat connections:
200 psig (1379 kPa) at 250°F (121°C)*

*Based on 95-5 Tin-Antimony

B. Valves 2 1/2" to 4" Pipe Size, Flanged Valves 4" to 12" Pipe Size, Flanged or Grooved

VALVE DESIGN AND CONSTRUCTION

Valve shall be of heavy-duty (select one: cast iron [flanged models only] or ductile iron [grooved models only]) construction with (select one: 125 psi [862 kPa] ANSI flanged or standard cut groove) connections suitable up to 175 psi (1207 kPa) working pressure. Valves 2 1/2"-3" pipe shall have a brass ball with glass and carbon filled TFE seat rings.

Valves 4"-12" shall be fitted with a bronze seat, replaceable bronze disc with EPDM seal insert, and stainless steel stem. Valves to have memory stop feature to allow valve to be closed for service and then reopened to set point without disturbing balance position. All valves to have calibrated nameplate to assure specific valve setting. Valves to be leak-tight at full rated working pressure.

DESIGN PRESSURE/TEMPERATURE

175 psig (1207 kPa) at 250°F (121°C)

IMPORTANT

When monitoring system flow, care must be exercised to avoid direct skin or eye contact with liquids that may escape. Liquids with temperatures in excess of 120°F (49°C) may cause burns.

To retain calibrated accuracy, a minimum length of unrestricted straight pipe adjacent to the valve should be maintained as follows:

| SIZE | UPSTREAM "A" (In Pipe Diameters) | DOWNSTREAM "B" (In Pipe Diameters) |
|---------|-------------------------------------|---------------------------------------|
| 1/2"-3" | 3 | 1 |
| 4"-12" | 5 | 2 |

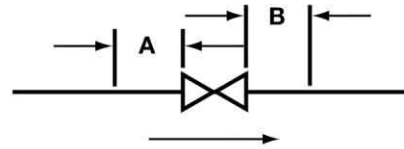

Bell & Gossett

USA
Bell & Gossett
8200 N. Austin Avenue
Morton Grove, IL 60053
Phone: (847) 966-3700
Facsimile: (847) 966-9052
www.bellgossett.com



INTL.
Bell & Gossett / Export Dept.
8200 N. Austin Avenue
Morton Grove, IL 60053
Phone: (847) 966-3700
Facsimile: (847) 966-8366
www.bellgossett.com

CANADA
Fluid Products Canada
55 Royal Road
Guelph, Ontario,
N1H 1T1, Canada
Phone: (519) 821-1900
www.itfpc.ca